

DELUXE STITCHER

C O M P A N Y I N C .

Head Serial Number : _____

Date Purchased : _____

Where Installed: _____

(make/model of machine)

DB75, DB75V & DB75VS

OPERATION AND MAINTENANCE MANUAL

DB75HD231/2.....Stitcher Head....23 Wire

DB75HD251/2.....Stitcher Head.....25 Wire

DB75HD20241/2..Stitcher Head..20x24 Wire

DB75VHD231/2...Stitcher Head...23 Wire

DB75VHD251/2....Stitcher Head.....25 Wire

DB75VHD20241/2..Stitcher Head..20x24 Wire

DB75VSHD231/2...Stitcher Head...23 Wire

DB75VSHD251/2....Stitcher Head.....25 Wire

DB75VSHD20241/2..Stitcher Head..20x24 Wire

Before using this Stitcher Head, all operators must study this manual and follow the safety warnings and instructions. Keep these instructions with the Stitcher Head for future reference. If you have any questions, contact your local DeLuxe Stitcher Representative or Distributor.

WARNING!

DB75/75V/75VS Heads

Machine operators and others in the work area should always wear safety glasses to prevent serious eye injury from fasteners and flying debris when loading, operating, or unloading the stitcher machine.

Do not operate this stitcher head without all stitcher machine guards in place. Do not modify the guards in any way. Always disconnect the power supply before removing any guards for servicing.

Never operate the machine with wire feeding through the head unless there is stock above the clinchers, otherwise serious damage may result.

Always turn power off when making adjustments. Always disconnect the power cord before any disassembly work.

Table of Contents

Introduction	3
Specifications.....	4
Installation	5
Pre-Inspection	5
Inspection	5
Mounting	6
Assembly	6
Operation	8
Wire Threading	8
Wire Straightening	10
Adjustments and Settings	11
Maintenance.....	13
Lubrication	14
Troubleshooting.....	16
Appendices	18
Exploded Drawings.....	18
Part Number/Description Cross Reference	31
Registration Card	33
Wear/Replacement Parts.....	34
Warranty	35

Introduction

The DeLuxe Stitcher Müller-Martini Replacement Heads, along with a complete line of fully interchangeable replacement parts are available for current Müller-Martini users. Anywhere the HK75, HK75V and HK75VS are utilized the DeLuxe Stitcher DB75HD, DB75VHD, & DB75VSHD can be used.

The DB75HD has a stitching capacity from 2 sheets up to 5mm (.197") and will accommodate wire sizes from 20-28 gauge round as well as 21 x 25 and 20 x 24 flat. The perfect replacement head for Müller-Martini Stitchers 221, 235, 321, 335, Prima, Bravo and more, the DB75HD is completely interchangeable.

The DB75VHD & DB75VSHD have a stitching capacity from 2 sheets up to 6mm (.236) and will accommodate wire sizes from 20-28 gauge round as well as 21 x 25 and 20 x 24 flat. This replacement head for Müller-Martini Stitchers 301, Tempo, Optima, Supra and the like, is also completely interchangeable.

Each of these heads weighs 7 lbs (3.2 kgs.) independently. The packaged shipping weight including the Wire Guide Spring, Clincher Plate assembly and user manuals is 10 lbs. (4.5 kgs.).

Always use a high quality Galvanized Wire so the plating does not peel. Excessive peeling will cause clogging and the premature wear of many components. Use the following chart as a guide for wire gauge usage.

2 sheets - 1/8" (3mm)	25 gauge
1/8" (3mm) - 7/32" (6mm)	23 or 24 gauge
For heavy paper	20 to 22 gauge round or 20x24 flat

NOTE: ALL PRODUCTS ARE MANUFACTURED BY DELUXE STITCHER.

Specifications

Weight

Shipping Weight	10 lbs (4.5 kg)
Box Dimensions	21" x 10" x 7" (53 x 25 x 18 cm)
Stitcher Head	
DB75HD	7 lbs (3.2 kg)
DB75VHD	7 lbs (3.2 kg)
DB75VSHD	7 lbs. (3.2 kg)

Physical Dimensions

Height	8.5" (22 cm)
Width	3.5" (9 cm)
Depth	4.25" (11 cm)

Stitching Capacity

DB75HD	Two Sheets to 13/64" (5 mm)*
DB75VHD	Two Sheets to 1/4" (6 mm)*
DB75VSHD	Two Sheets to 1/4" (6mm)*

Wire Types	20 through 28 round or 21 x 25 and 20 x 24 flat
------------	----------------------------------------------------

Stitcher Machine Compatibility

.....	Valore
.....	Minuteman
.....	Fox, 221, 235
.....	Bravo
.....	Presto, 300
.....	Prima, 331, 335
.....	301 (DB75VS only)
.....	Optima (DB75VS only)
.....	Tempo (DB75VS only)
.....	Supra (DB75VS only)

* Actual stitching thickness capacity depends on the type of stock being stitched and the capacity of the saddle stitcher being used.

Installation

Pre-Inspection

Carefully inspect the condition of the shipping container before unpacking your replacement Head for Müller-Martini Stitchers. If the container is broken or damaged and there is evidence that the

stitcher head may be damaged, immediately notify the carrier who delivered the head and the DeLuxe Stitcher Graphic Arts Representative from whom the Head was purchased.

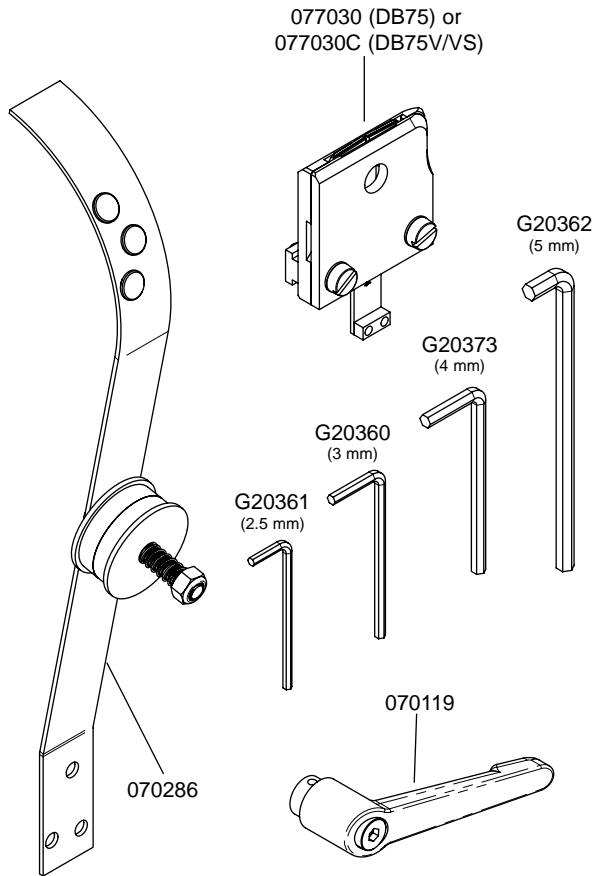

Figure 1 - Inspection

Inspection (Figure 1)

As you carefully unpack the replacement head, check to make sure all components were delivered and are in good working order. Use **Figure 1** in this manual for reference to the following pieces:

- Replacement Head for Müller Martini Stitchers: DB75HD, DB75VHD or DB75VSHD
- Wire Guide Spring [070286]
- Clincher Plate Assembly [077030 or 077030C]
- Feed Release Handle [070119]
- 2.5, 3, 4 and 5 mm Hex Key Wrenches [G20361, G20360, G20373 and G20362]
- Stitch samples

Mounting & Assembly (Figure 2-6)

Attaching the Feed Release Handle (Figure 2)

From out of the box, secure the Feed Release Handle [070119] to the Stitcher Head by slipping the Handle over the Feed Release Cam Assembly [070118] and securing it with the provided screw, inserting it through the Spring. Make sure the Handle is angled toward the outside of the Head when you the screw is tightened.

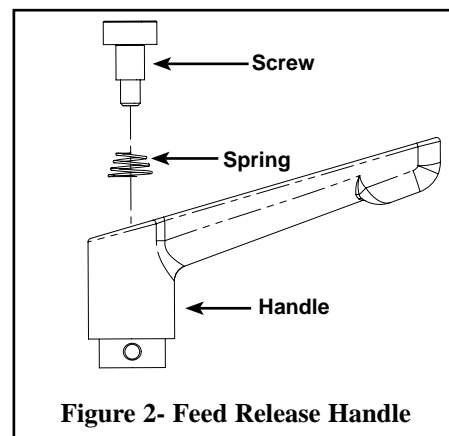

Figure 2- Feed Release Handle

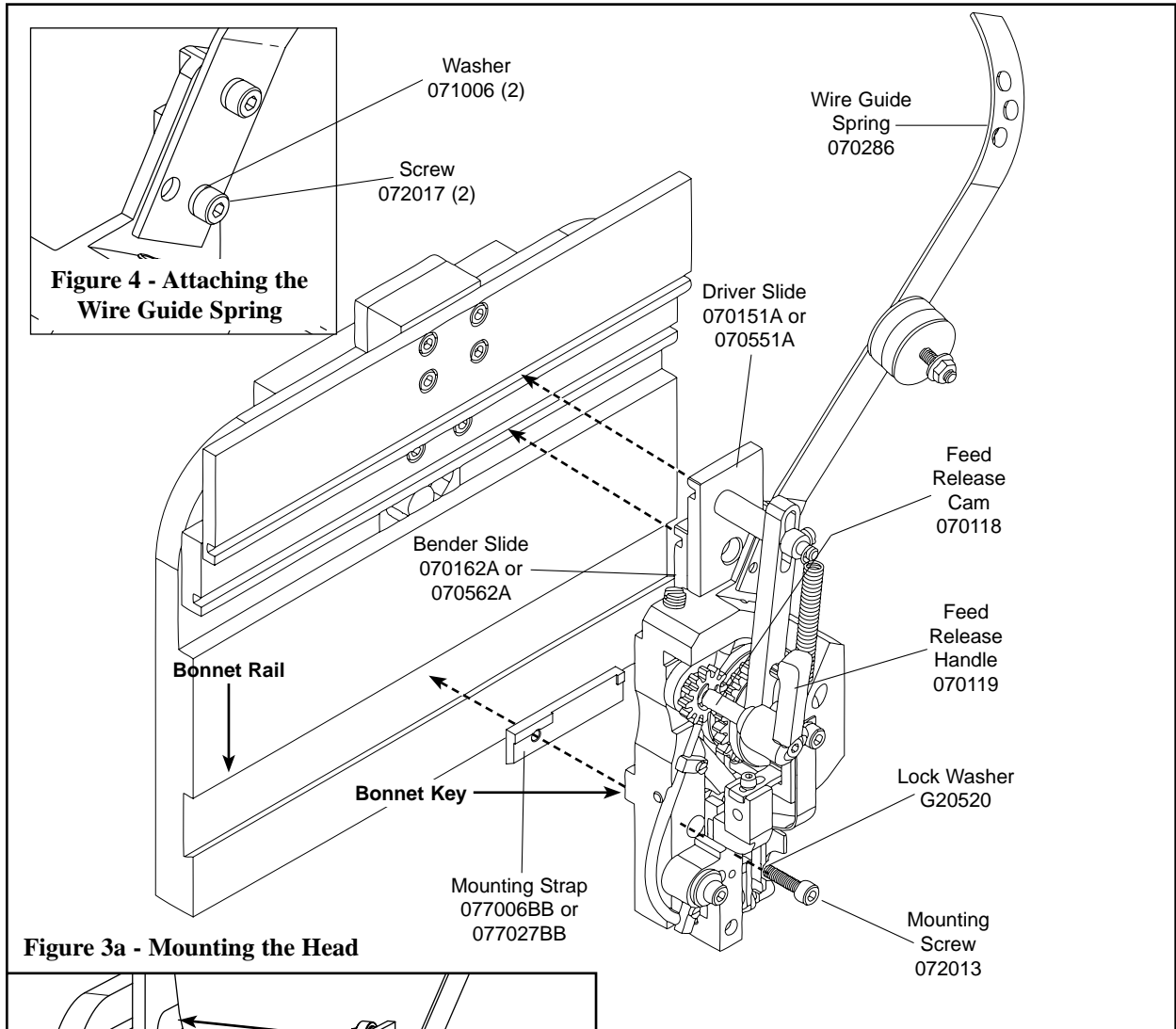

Figure 3a - Mounting the Head

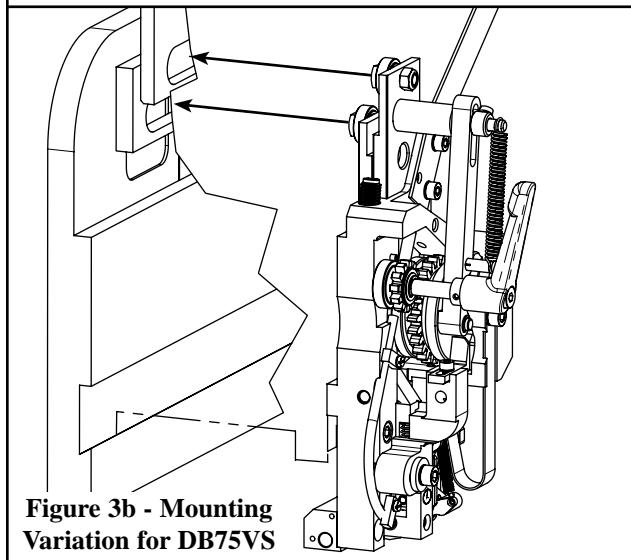

Figure 3b - Mounting Variation for DB75VS

Mounting the Head (See Figure 3)

Attaching the Wire Guide Spring (Figure 4)

Mounting the Clincher Plate (Figure 5 & 6)

Figure 5 - Mounting Clincher Plate Assembly

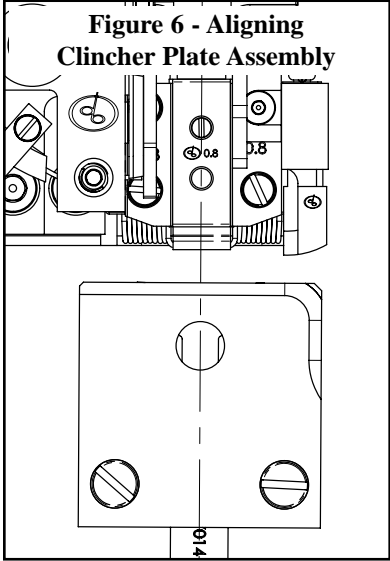
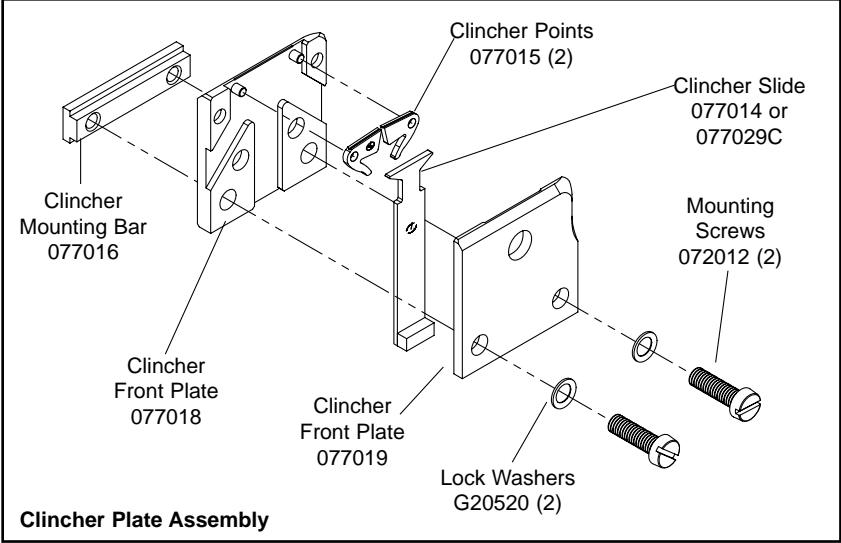
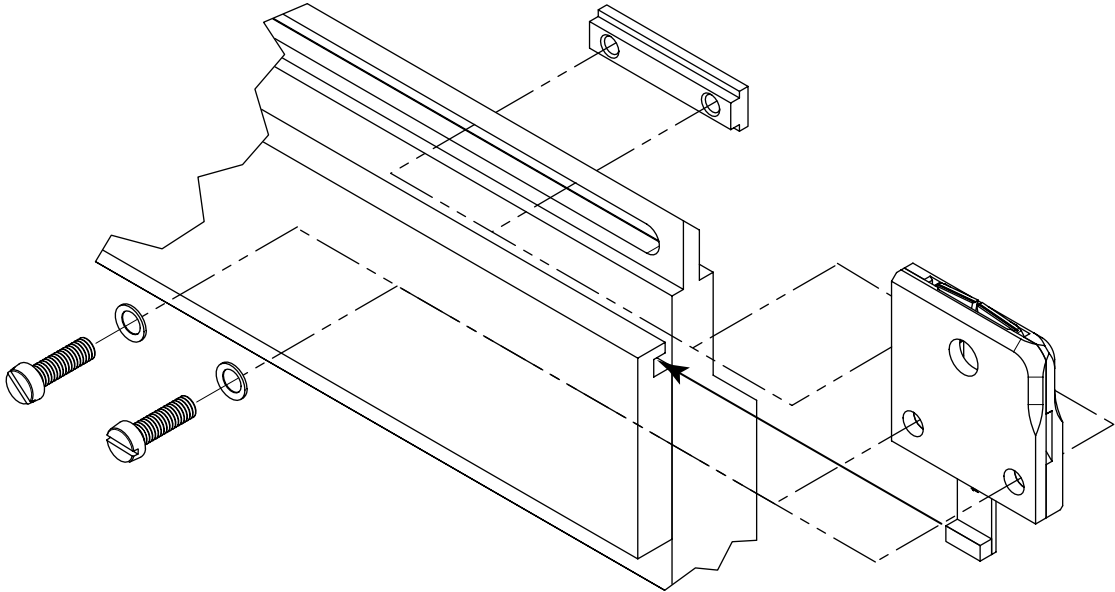

⚠ CAUTION

Always disconnect the power before assembling or making adjustments to your stitcher machine.

Operation

Wire Threading (Figure 7-8)

Figure 7 - Wire Threading

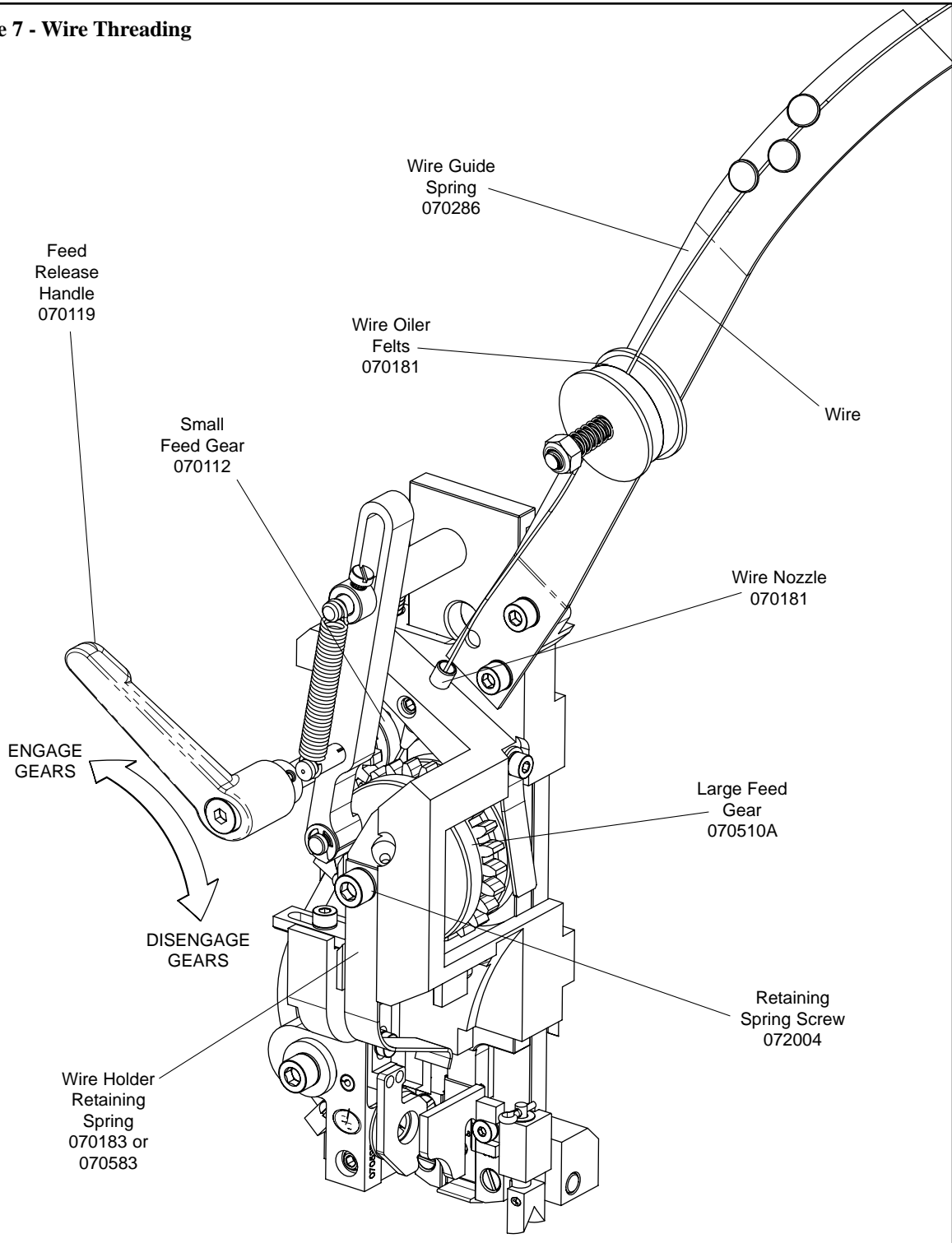

Before the Stitcher Machine is turned on, release the Wire Holder Assembly [070135A] (*Not shown- See Fig. #*) secured by the Wire Holder Retaining Spring [070183 or 070583] by loosening the Screw [072004] on the front of the Head. Thread the wire from the Spool under the studs on the Wire Guide Spring (070286), between the Wire Oiler Felts [G20293] on the Spring and into the Wire Nozzle [070181]. Turn the Feed Release Handle [070119] clockwise so that the Small Feed Gear [070112] is disengaged from the Large Feed Gear [070510A].

Continue to push wire through the Replacement Head until the end of the wire passes the Small and Large Feed Gears, enters the Wire Tube [070544] and begins to come out the bottom of the Wire Tube. Then using a small screw driver, wedge the wire up until it enters the Fixed Wire Cutter [070600C]. Engage the Small and Large Feed Gears by turning the Adjustable Lever counter-clockwise.

Note: It will take two full cycles for the proper length staple to come out of the Head.

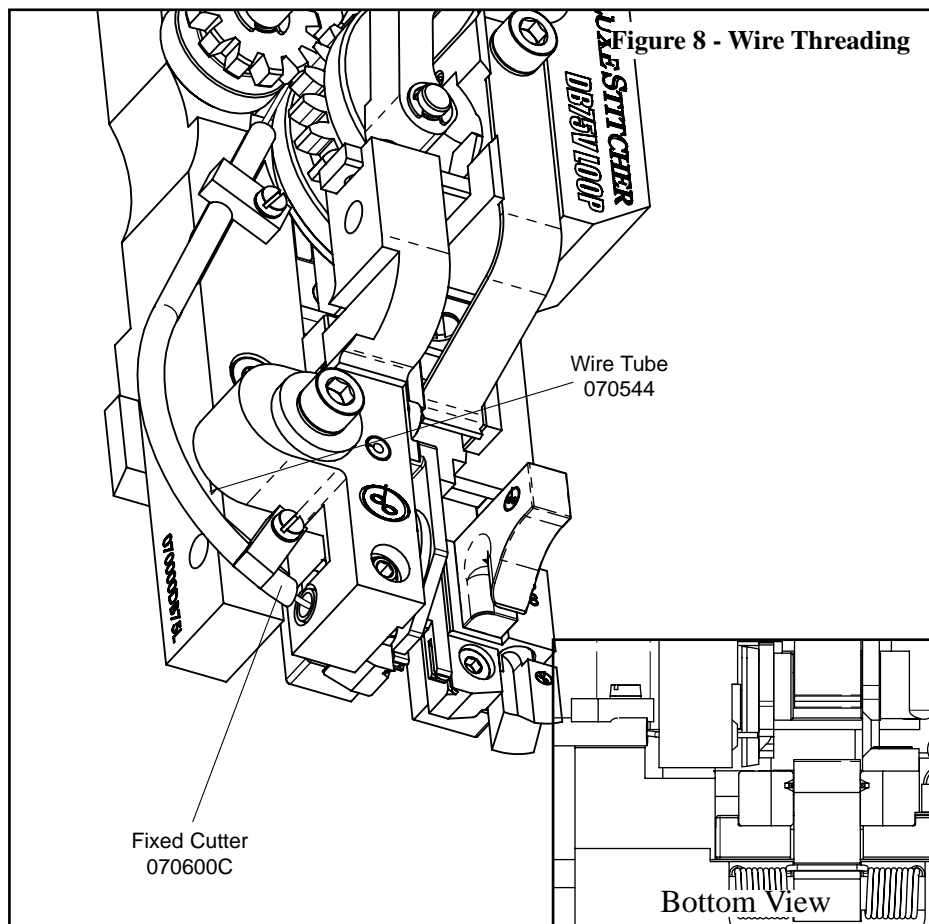

Wire Straightening (Figure 9)

Once threaded, cycle the Stitcher Machine and watch the wire feeding out of the the Cutter Box [070197A or 070597A] to the right of the Moving Cutter [070145C]. The wire should be traveling in an approximate horizontal direction when exiting the Cutter Box.

Top-to-Bottom Adjustment

If the Wire is feeding in an upward or downward direction, the Wire Straightener [070206A] will have to be adjusted. Loosen the Screw [G20589] securing the Wire Straightener to the Cutter Box. If the wire is feeding in an upward direction, slide the Wire Straightener down slightly. Conversely, if the wire is feeding in a downward direction, slide the Assembly up slightly. Make sure to tighten the Screw after every adjustment to see accurate results. Allow enough Wire to be fed through the Head so that an accurate assessment can be made. Make sure the ends of each cut piece of Wire is free of burrs, which would negatively affect the driving and clinching of the formed Wire.

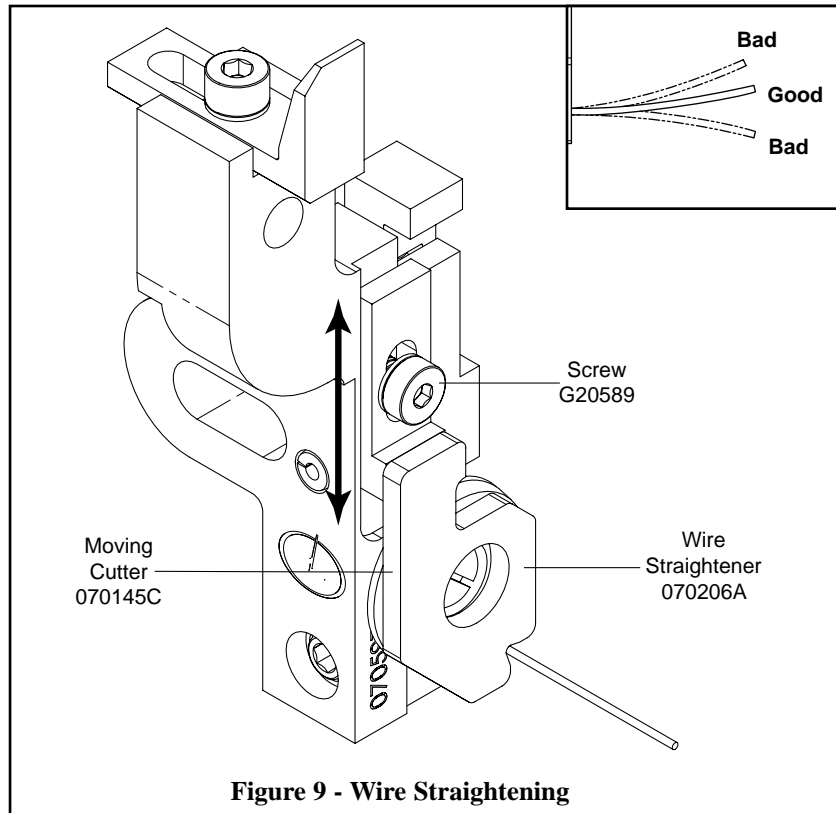

Figure 9 - Wire Straightening

Make sure the Wire Holder Assembly has been removed before tripping the Machine to avoid jams and the chipping of parts.

⚠ WARNING

Adjusting the Length of the Right Leg (Figure 10-12)

Setting the Stitch's Right Leg (& Setting It's Center)

If after a few stitches, the length of the stitch's right leg is too short or too long, you will need to make adjustments. Adjustments are always made to the right leg to compensate for the length of the left leg. First adjust the stitch's right leg to match the left and then make adjustments for the overall length of the stitch or wire draw.

Power off the Stitcher Machine and release the Extension Spring [074002] from the Feed Gear Operating Lever Pin [043002] on the Replacement Head. Disengage the Small Feed Gear from the Large Feed Gear by turning the Feed Release Handle [070119]. Push the Feed Gear Operating Lever [077001] down which will move the pin on the Feed Gear Pinion [070111A] out of the way of the Feed Gear Stop [077026]. Loosen, but do not remove, the Screw [G20589] securing the Feed Gear Stop to the top of the Cutter Box Assembly. If the legs of the stitch are not even, do one of the following:

If the right leg is too short, slide the Feed Gear Stop to the left slightly, to lengthen it.

If the right leg is too long, then adjust the Feed Gear Stop slightly to the right.

Tighten the screw and replace the Extension Spring.

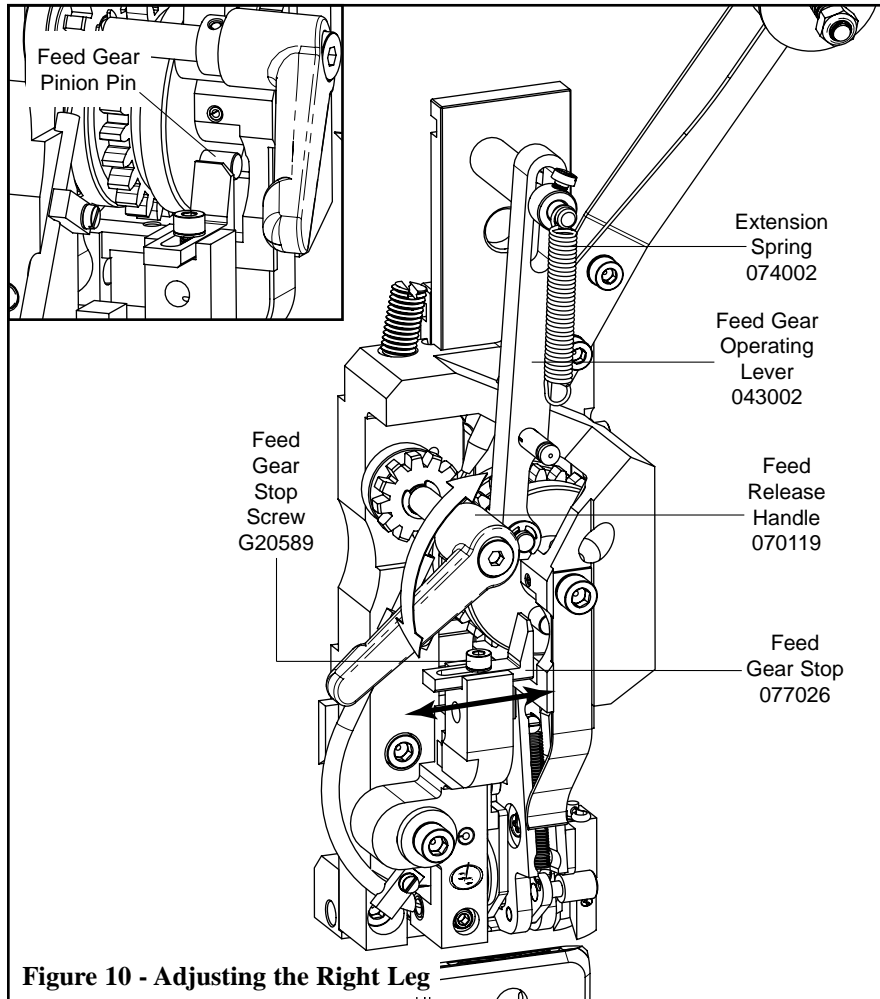

Figure 10 - Adjusting the Right Leg

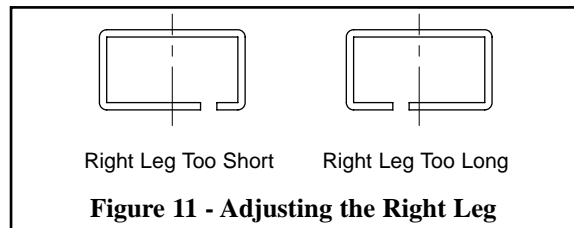

Figure 11 - Adjusting the Right Leg

Always disconnect the power before assembling or making adjustments to your stitcher machine.

CAUTION

Power on the Stitcher Machine and jog the Stitcher to observe the length of the stitch's right leg after the initial adjustment. Continue to make adjustments and re-test the Head until the length of the stitch's right leg is satisfactory.

When set, any one of the above stitches are regarded as good stitches with the two on the left needing the next step in adjustment and the two on the right as properly set (with amount of gap a matter of preference).

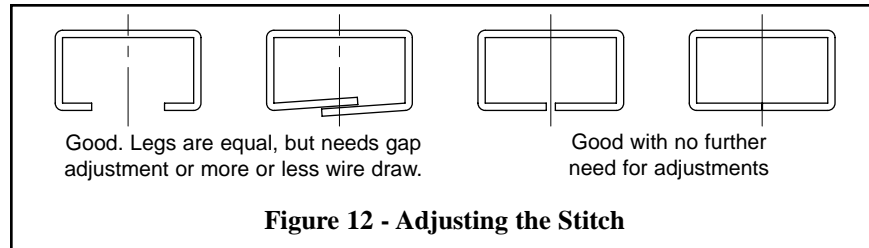

Adjusting the Stitch Gap or Wire Draw (Figure 13)

Adjusting the Overall Length of the Stitch (Adjusting the Stitch Gap)

To change the overall length of the stitch, or more specifically to change the gap between the legs of the stitch, the position of the Cutter Box must be adjusted. Begin by releasing the Extension Spring from the Feed Gear Operating Lever Pin. Disengage the Small Feed Gear and the Large Feed Gear by turning the Feed Release Handle. Push the Feed Gear Operating Lever down which will move the pin on the Feed Gear Pinion Pin out of the way of the Feed Gear Stop. Loosen the Screw [072006] securing the Cutter Box to the Stitcher Head.

If the legs are too short, increase the overall length of the stitch's legs by sliding the Cutter Box to the left and if too long, to the right. Tighten the Screw, attach the Extension Spring and power on the Stitcher Machine. Trip the Stitcher to observe the overall length of the each stitch after the initial adjustment. Repeat as necessary.

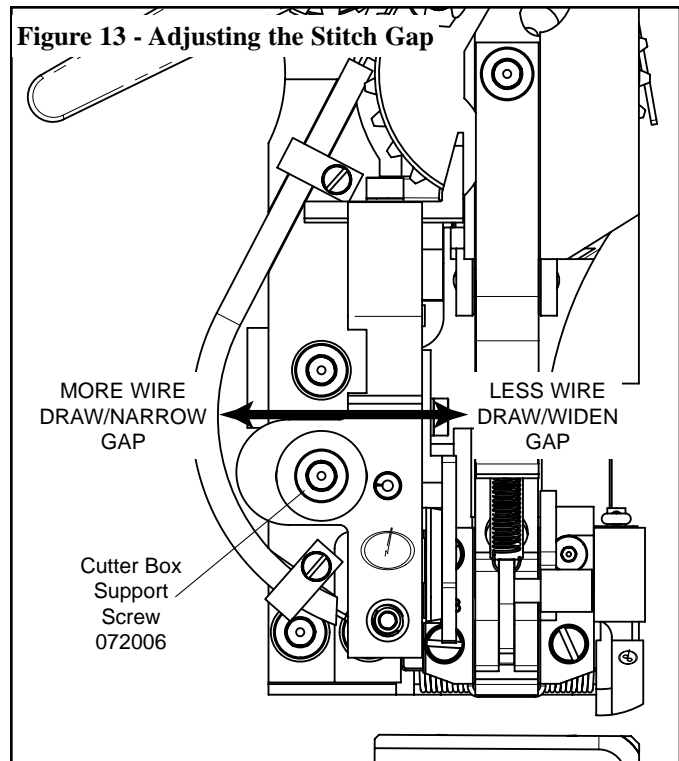

Adjusting the Clincher Points (Figure 14)

If the clinch on the staple is not tight enough, the Clincher Points [077015] have to be raised. Conversely, if the clinch is too tight, the Clincher Points have to be lowered. This adjustment is made on the Stitcher Machine and so cannot be completely explained in this manual as each individual Machine is different.

The final position of the Clincher Points should be flush (or slightly above flush) with the Clincher Plates. The best way to see the position of the Clincher Points is to jog the Machine where the Driver is at the lowest position of its stroke, the Clincher Points are at their highest position. Jog the Stitcher Machine until the Stitcher Head is just past this point to reveal the Clincher Points' position. To be sure that the Points are at the best position possible, run a few test stitches and compare the clinched staples.

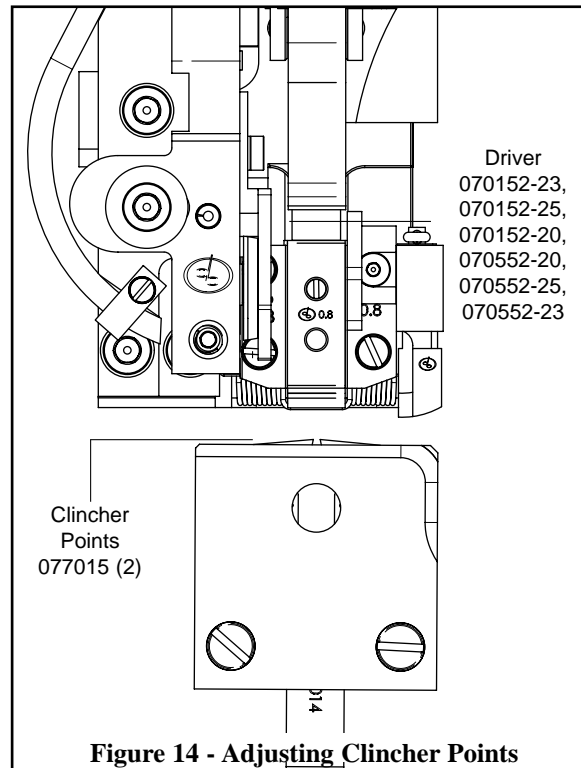

Always disconnect the power before assembling or making adjustments to your stitcher machine.

CAUTION

Maintenance

Lubrication (Figure 15)

Use any standard S.A.E. #10 oil for lubricating the heads. Heads that are in constant operation should be lubricated daily. Heads that are operated periodically should be lubricated every five pound wire spool change or every month, whichever comes first. Usually, only a drop of oil is required at each lubrication point. Care must be taken that those parts of the head that contact the work to be stitched are free of oil. Lubricate regularly instead of excessively. Excessive oiling will result in work becoming spotted with oil. Use one drop of oil in the following lubrication points:

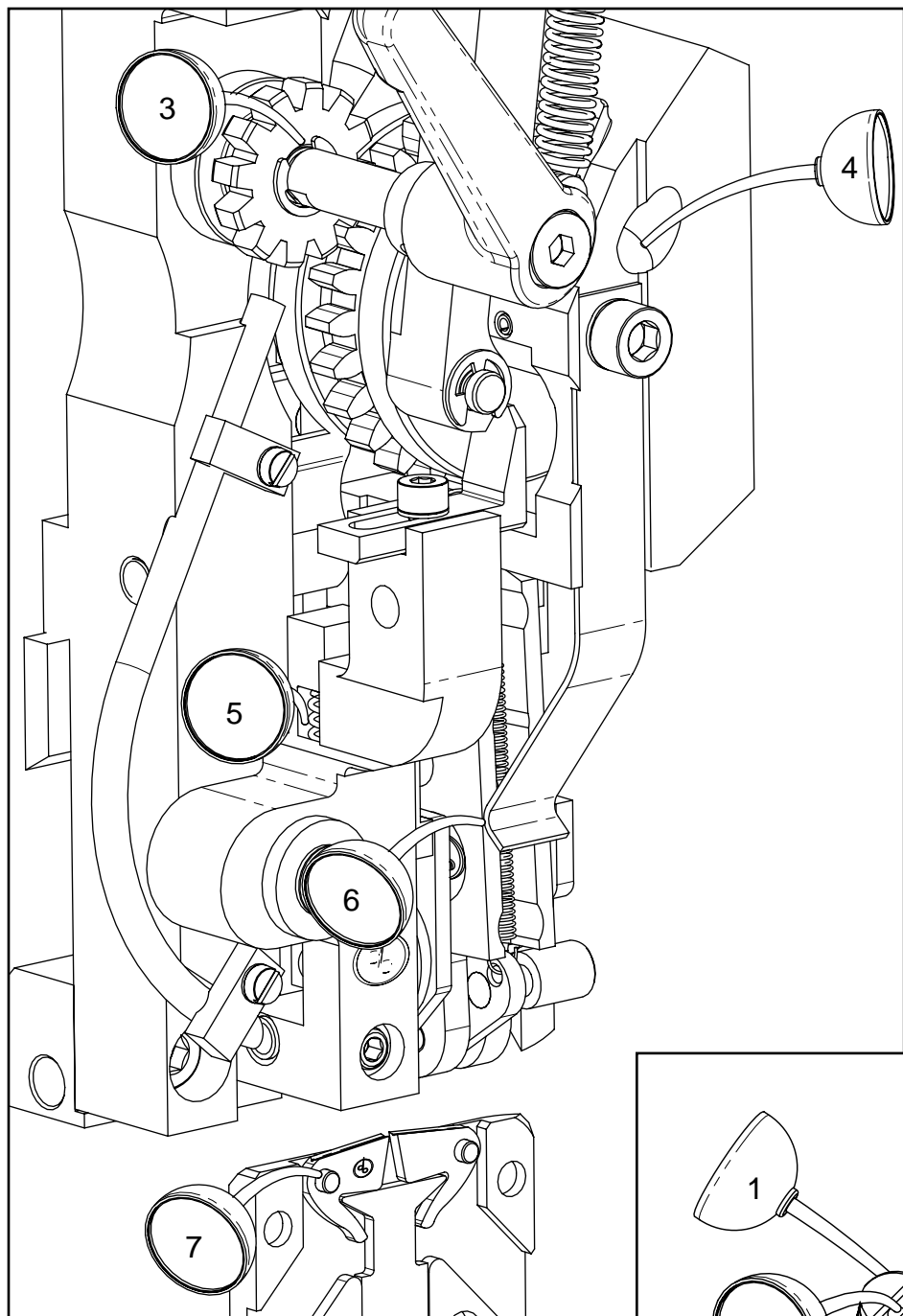

1. At the top of the Bonnet [070000 or 070500] on either side of the Driver Slide [070551A or 070151A] and Bender Slide [070162A or 070562A].

2. In the hole of the Feed Cam Plunger Bushing [077010].

3. On the shaft of the Feed Release Cam Assy. [070118] in the front of the Small Feed Gear [070112]

4. The oil hole in the front of the Bonnet [070000 or 070500] - this lubricates the Clutch Bearing located inside the Feed Gears

5. On the Cutter Operating Lever

[070230] behind the Cutter Box [070197A or 070597A].

6. In between the Wire Holder Retaining Spring [070183 or 070583] and the Wire Holder [070135A] and on the Hook Pivot Pin [073009] in the Wire Holder [070135A]

7. On each of the Clincher Point Pivot Pins [077018-2] on the Clincher Back Plate [077018]

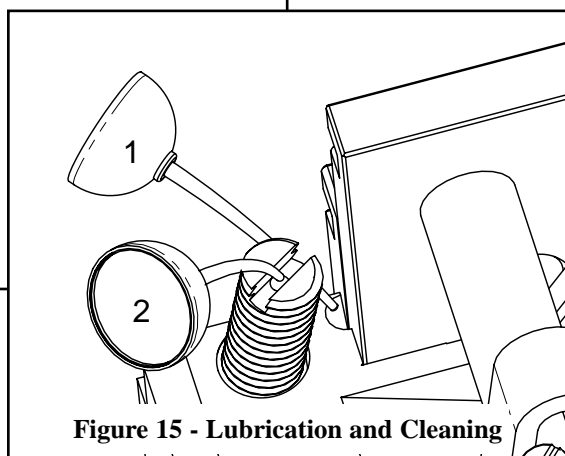

Figure 15 - Lubrication and Cleaning

Feed Gear Information (Figure 16)

Correct clutch assembly.

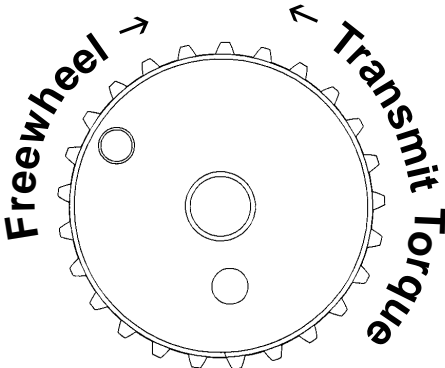

Figure 16 - Feed Gear Pinion Assy

Always disconnect the power cord before any maintenance is done or adjustments are made to the Müller Replacement Head

CAUTION

Troubleshooting (Figure 17)

The quality and quantity of work that can be produced with the Müller Replacement Head is dependent upon the operator making all adjustments as accurately as possible and carefully maintaining the head. The cause of staple imperfections usually can be traced to inaccurate settings or normal wear of moving parts. In the event of trouble of this nature occurring, the operator can, by referring to the following troubleshooting chart, quickly locate and remedy the cause or causes of the trouble.

The following is a brief list of problems and solutions which should cover the majority of situations encountered when stitching with the DB style Stitching Heads.

	<p>PROBLEM: Right Leg Short SOLUTION: Move the Feed Gear Stop to the right, slightly. (See page 11)</p>
	<p>PROBLEM: Right leg Long SOLUTION: Move the Feed Gear Stop to the left, slightly. (See page 11)</p>
	<p>PROBLEM: Corner Buckled SOLUTION: Check the Driver for a chipped corner and rotate or replace it if needed. Use a heavier gauge wire.</p>
	<p>PROBLEM: Leg(s) Buckled SOLUTION: Check the Wire Cutters and Wire Cutter Operating Slide for wear and rotate or replace if needed. Use a heavier gauge wire.</p>
	<p>PROBLEM: Crown Buckled SOLUTION: Check Supporter Spring tension on the Head. If it is too loose replace it.</p>
	<p>PROBLEM: Stitch in Pieces SOLUTION: Clean and lubricate the Head. Check for hard or brittle wire and replace. Check the tension of the Wire Holder Spring and replace Spring if too loose. Look for wear in Wire Holder pivot point in Bonnet.</p>

Figure 17 - Troubleshooting



PROBLEM: Loose Clinch

SOLUTION: Raise the Clincher Points. (See page 13)

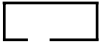
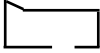
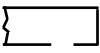
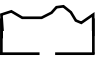
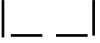
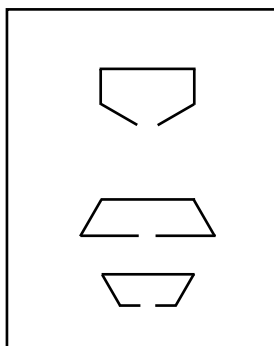
PROBLEM: Legs are Spread or Contracted

SOLUTION: Make sure the wire is feeding straight through the Head. (See page 10) Check the Wire Cutters for wear and rotate or replace if needed. Check the Formers for wear in the grooves and replace if needed.

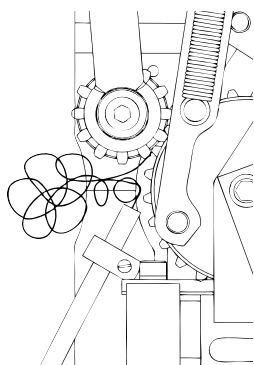

PROBLEM: Wire jam near Feed Gear

SOLUTION: Tighten Cutters. Check for the following worn parts and replace if necessary. Fixed Cutter, Moving Cutter, Cutter Operating Slide, Cutter Operating Lever, Bender Slide Insert, Wire Guide, Hook, Hook Pivot Pin and Feed Gear Friction Strip.

Figure 17 - Troubleshooting

DB75 Stitcher Head

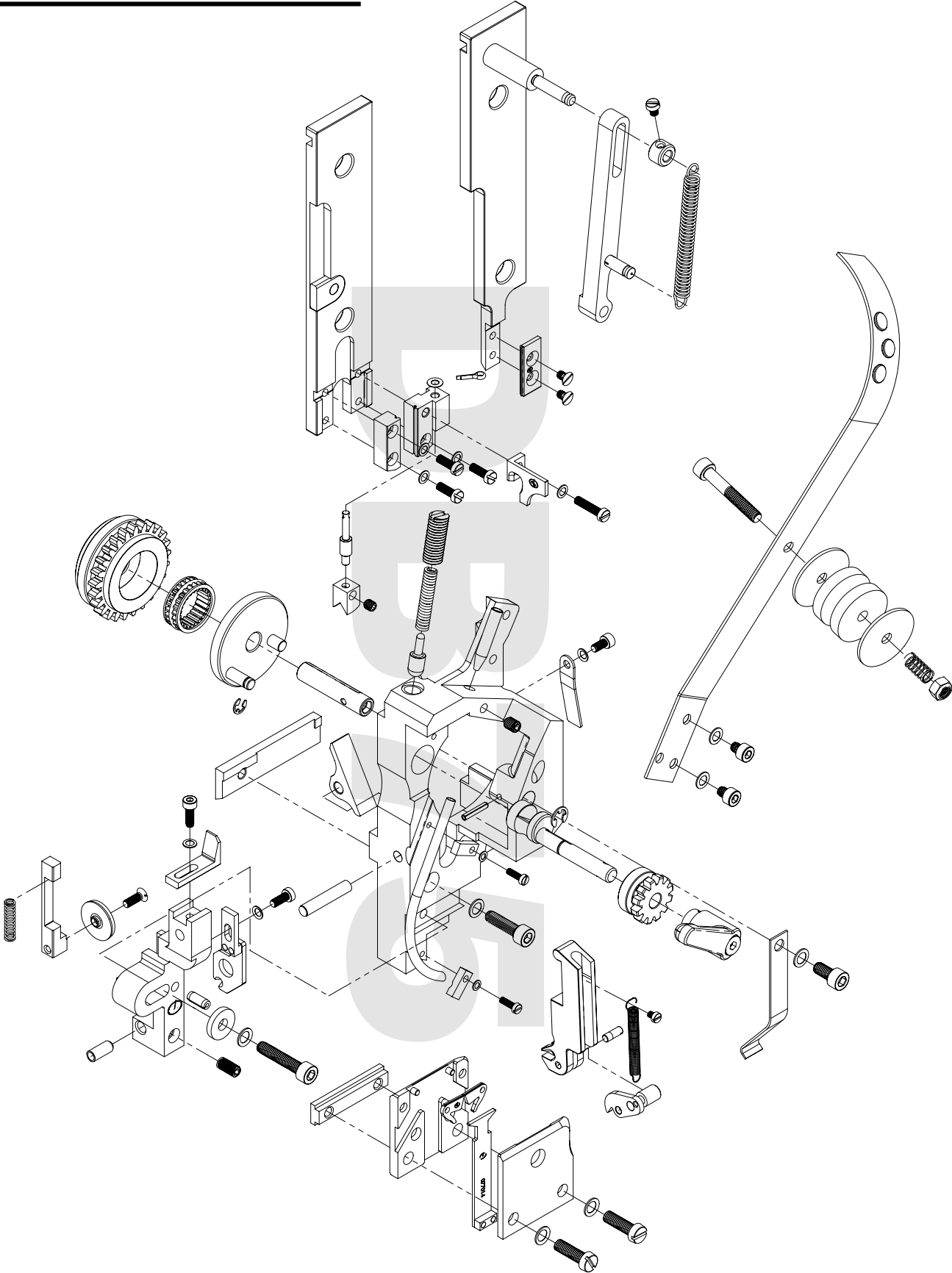

DB75V Stitcher Head

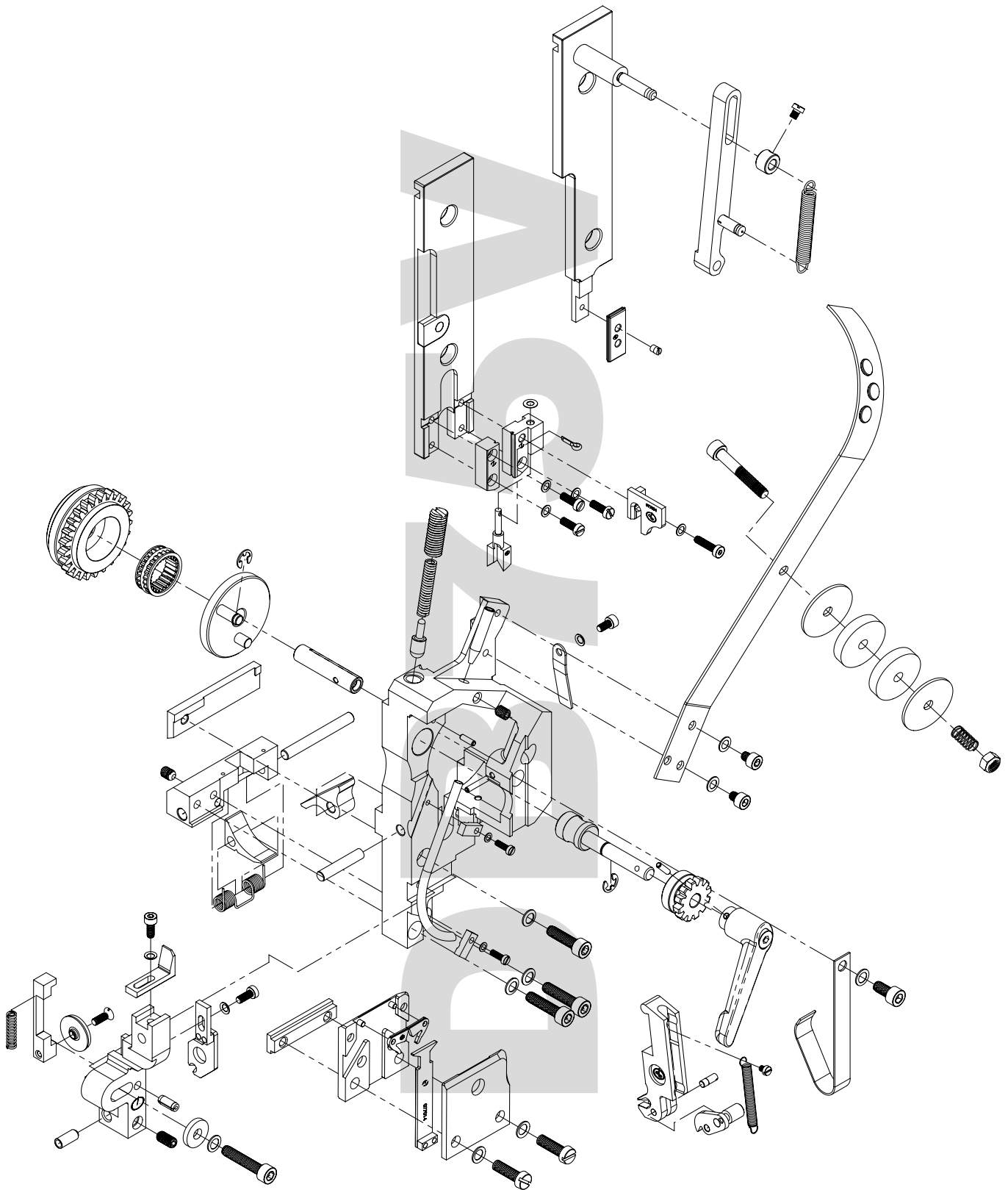

DB75VS Stitcher Head

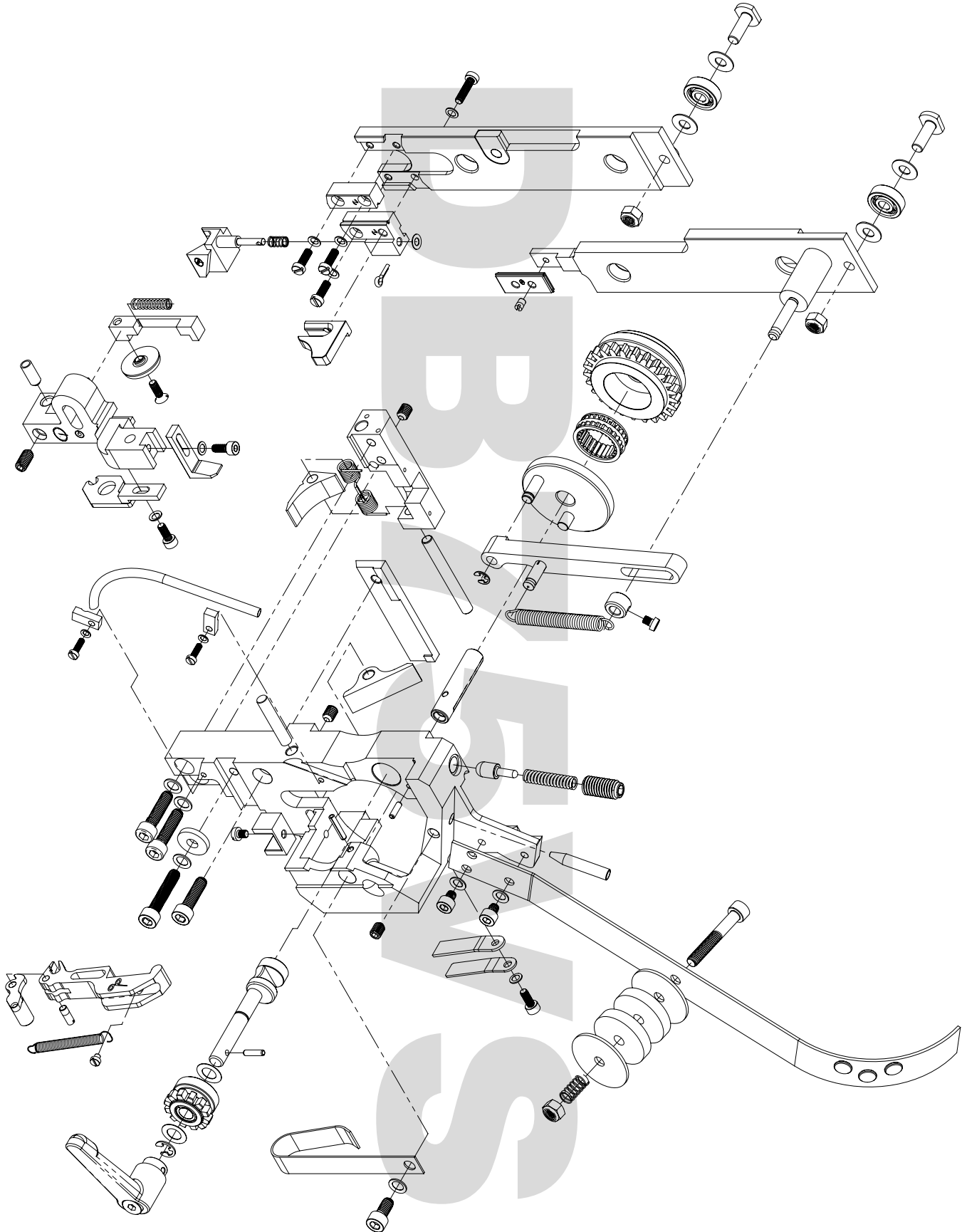

Bonnet and Wire Guide Spring Sub-Assemblies DB75

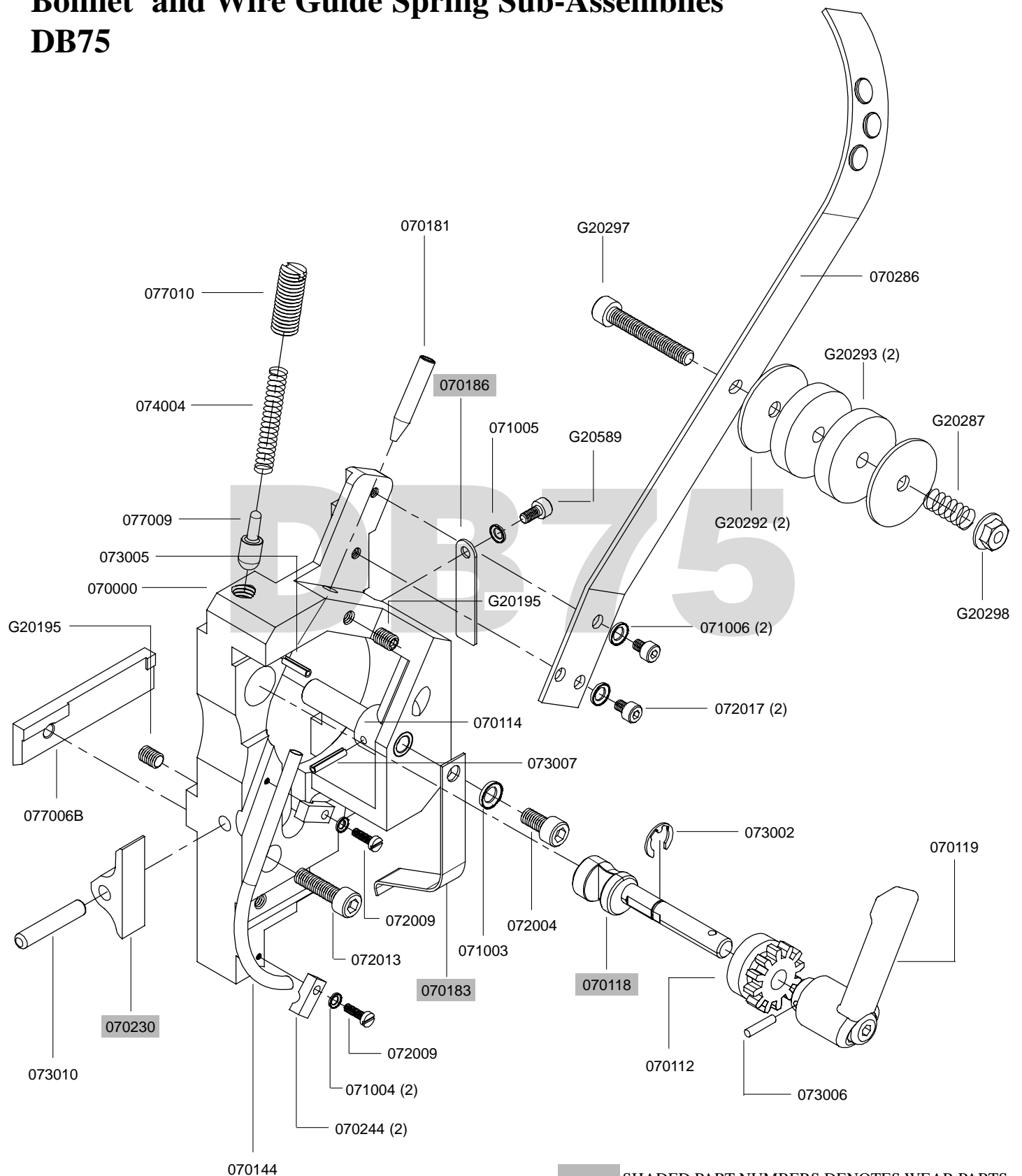

SHADED PART NUMBERS DENOTES WEAR PARTS

Bonnet and Wire Guide Spring Sub-Assemblies DB75V & DB75VS

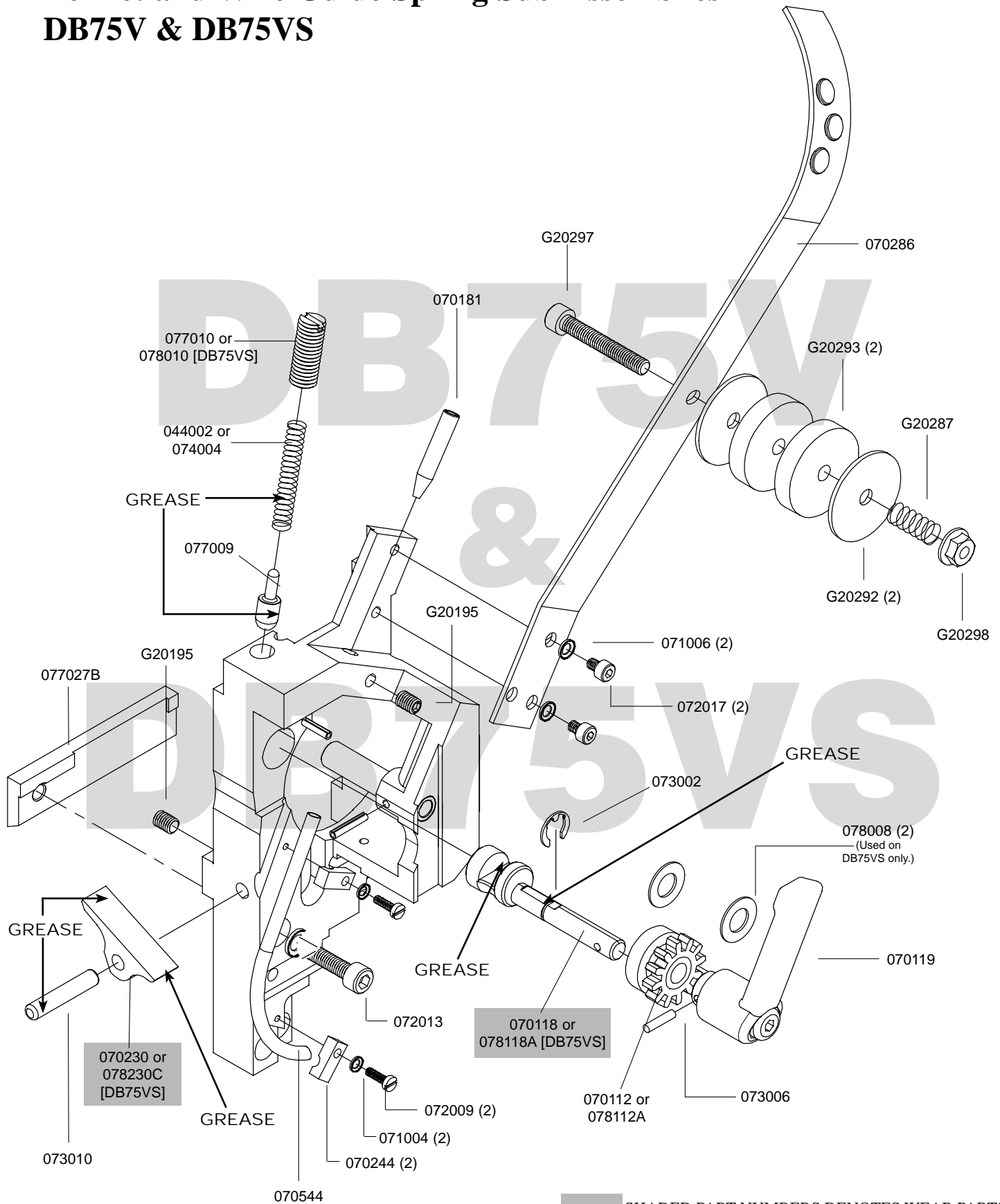

SHADED PART NUMBERS DENOTES WEAR PARTS

Bonnet and Supporter Sub-Assemblies DB75V & DB75VS

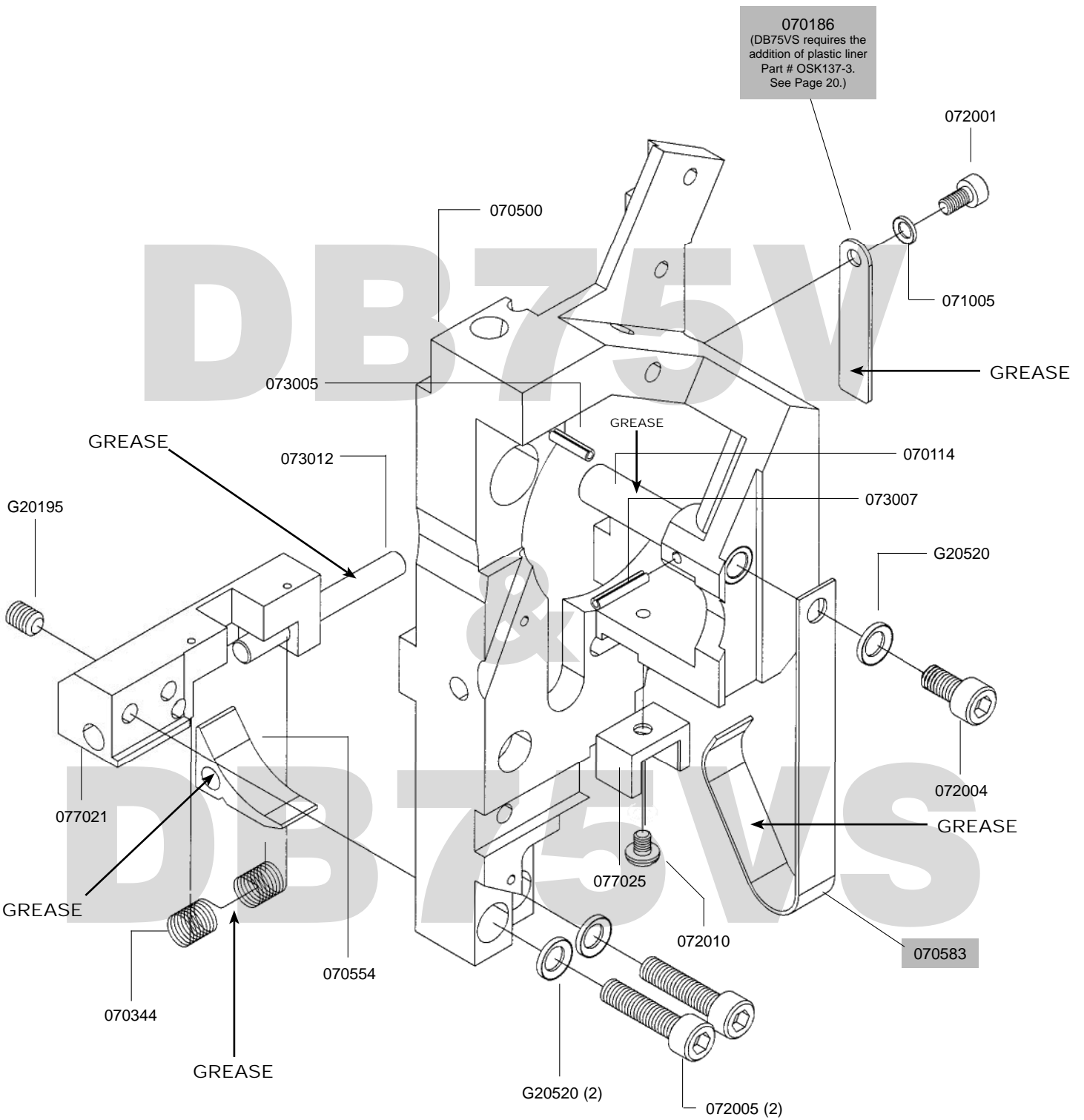

SHADED PART NUMBERS DENOTES WEAR PARTS

Driver and Bender Inserts DB75

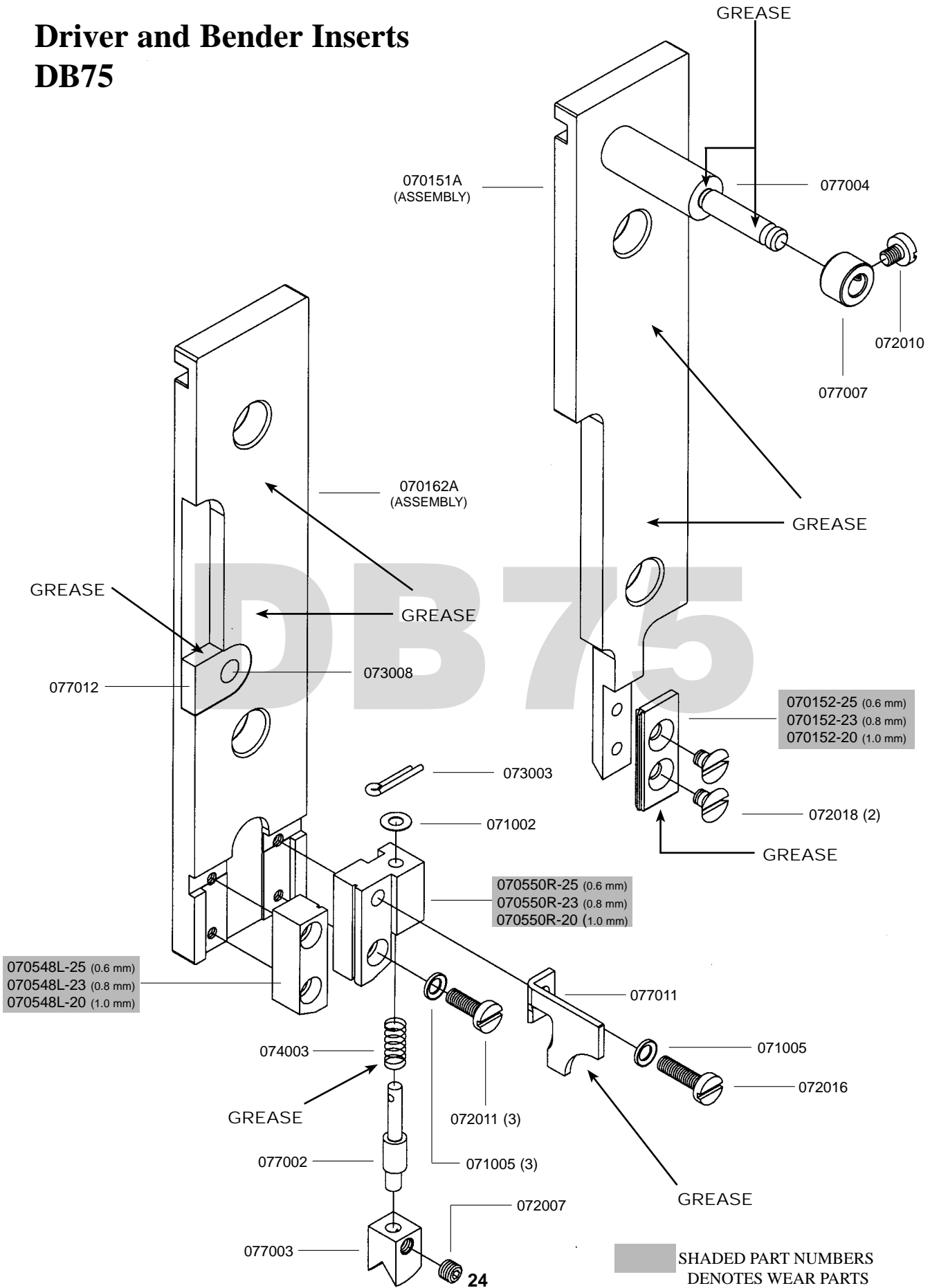

Driver and Bender Inserts DB75V

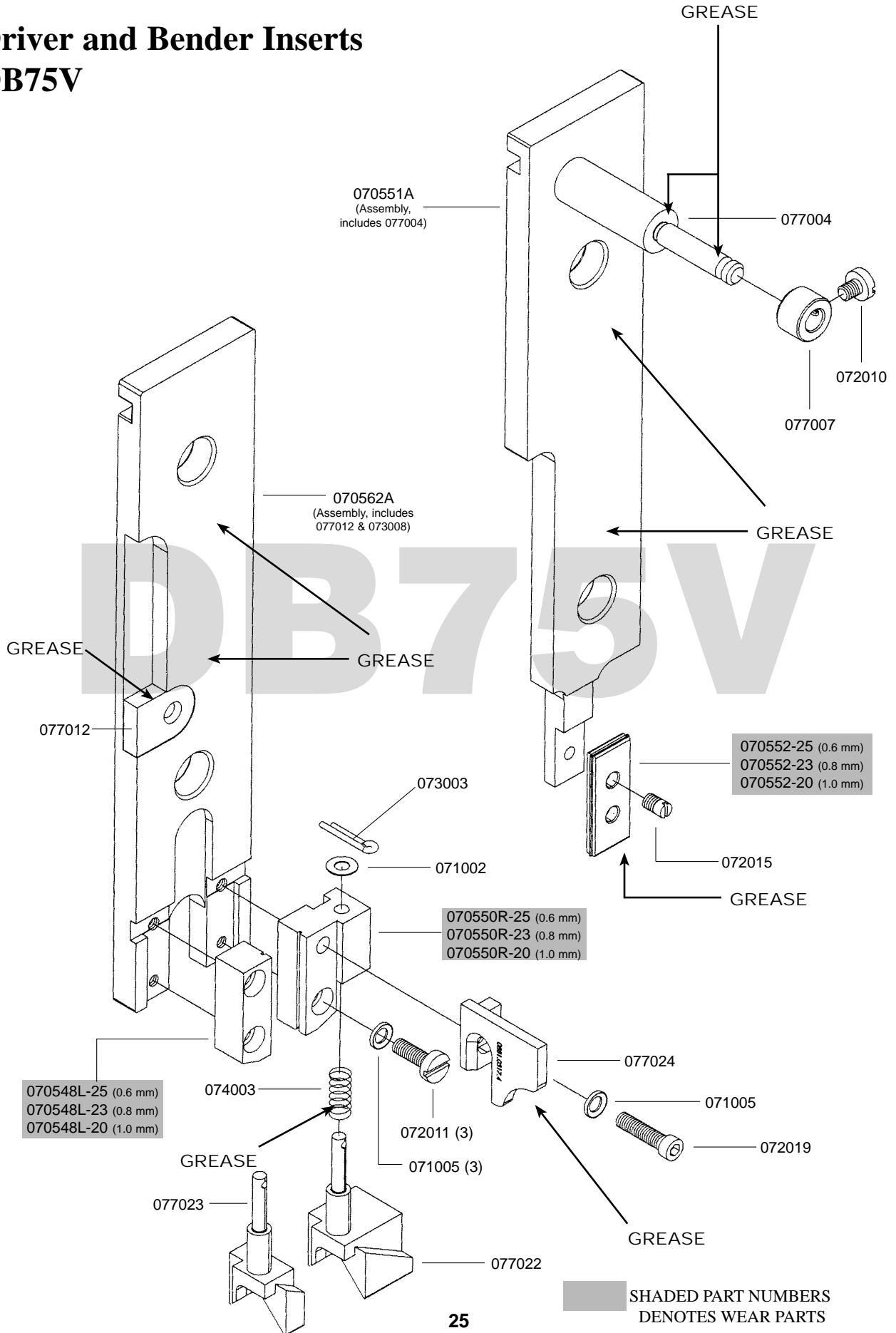

Driver and Bender Inserts DB75VS

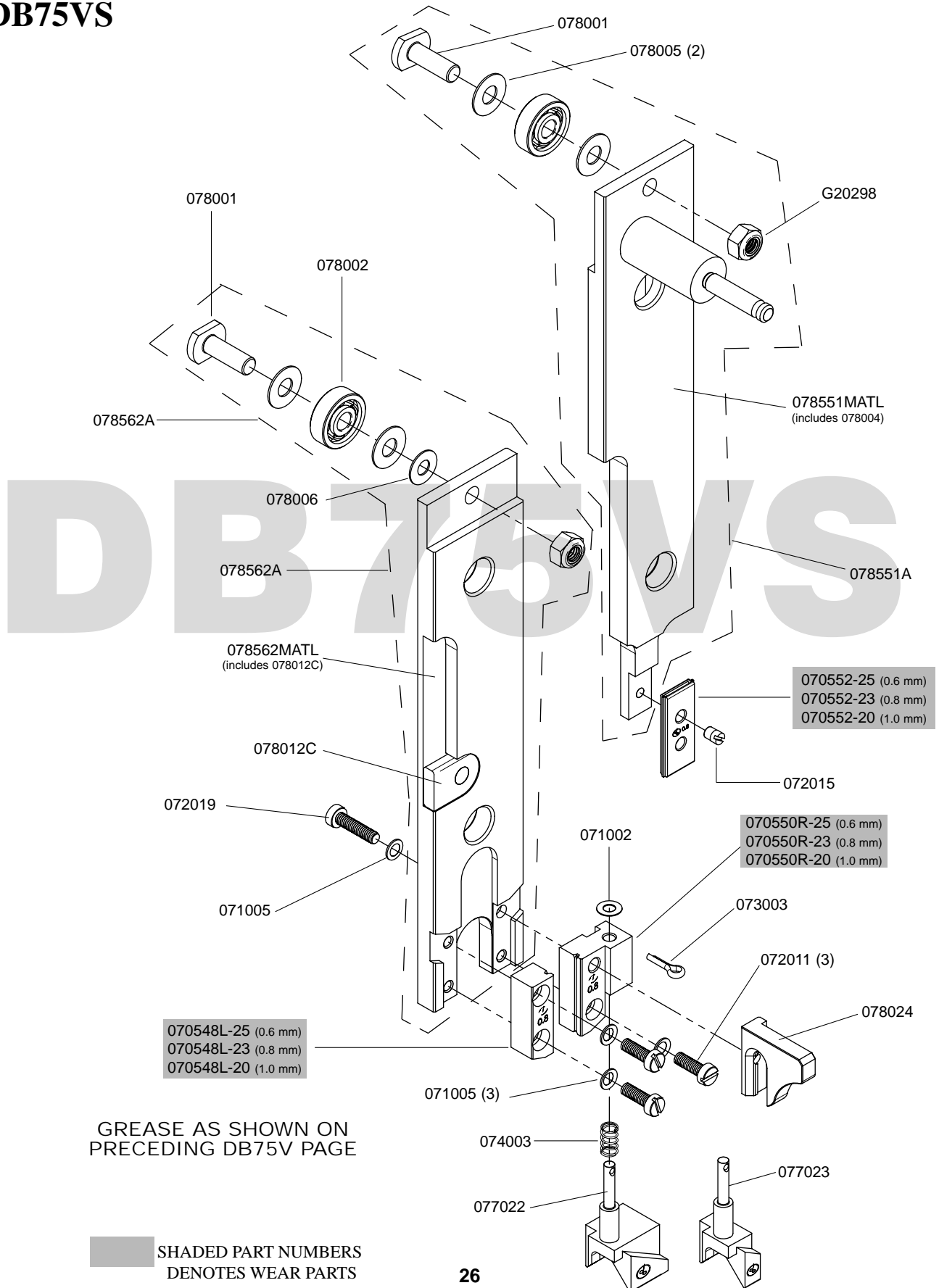

Cutter Box Assembly

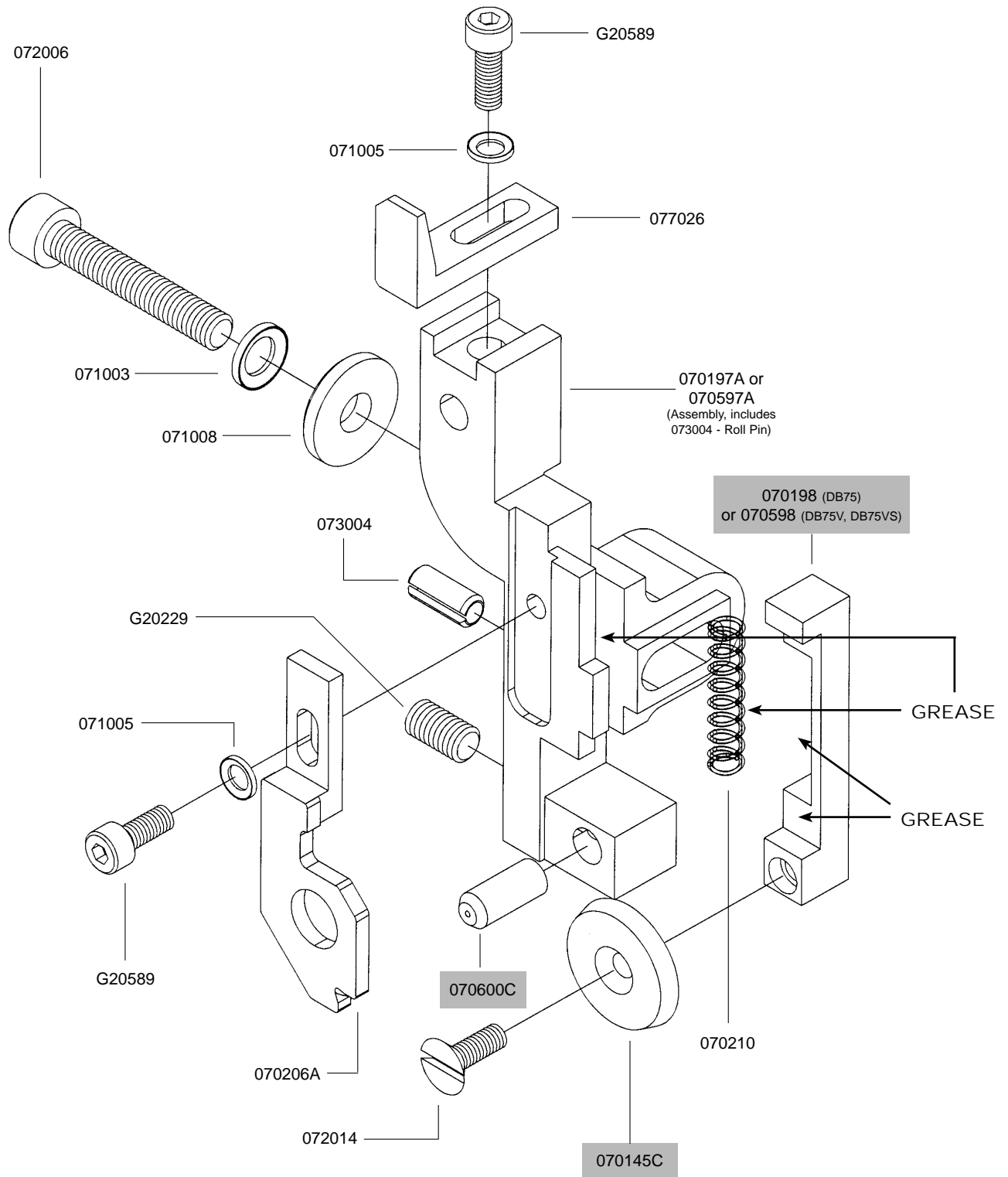

Feed Gear Assembly - DB75, DB75V & DB75VS

Replacement kits:

MMKFG1 (for DB75) [Also replaces Feed Gear Assy for HK75]

MMKFG2 (for DB75V or DB75VS) [" " " HK75V or HK75VS]

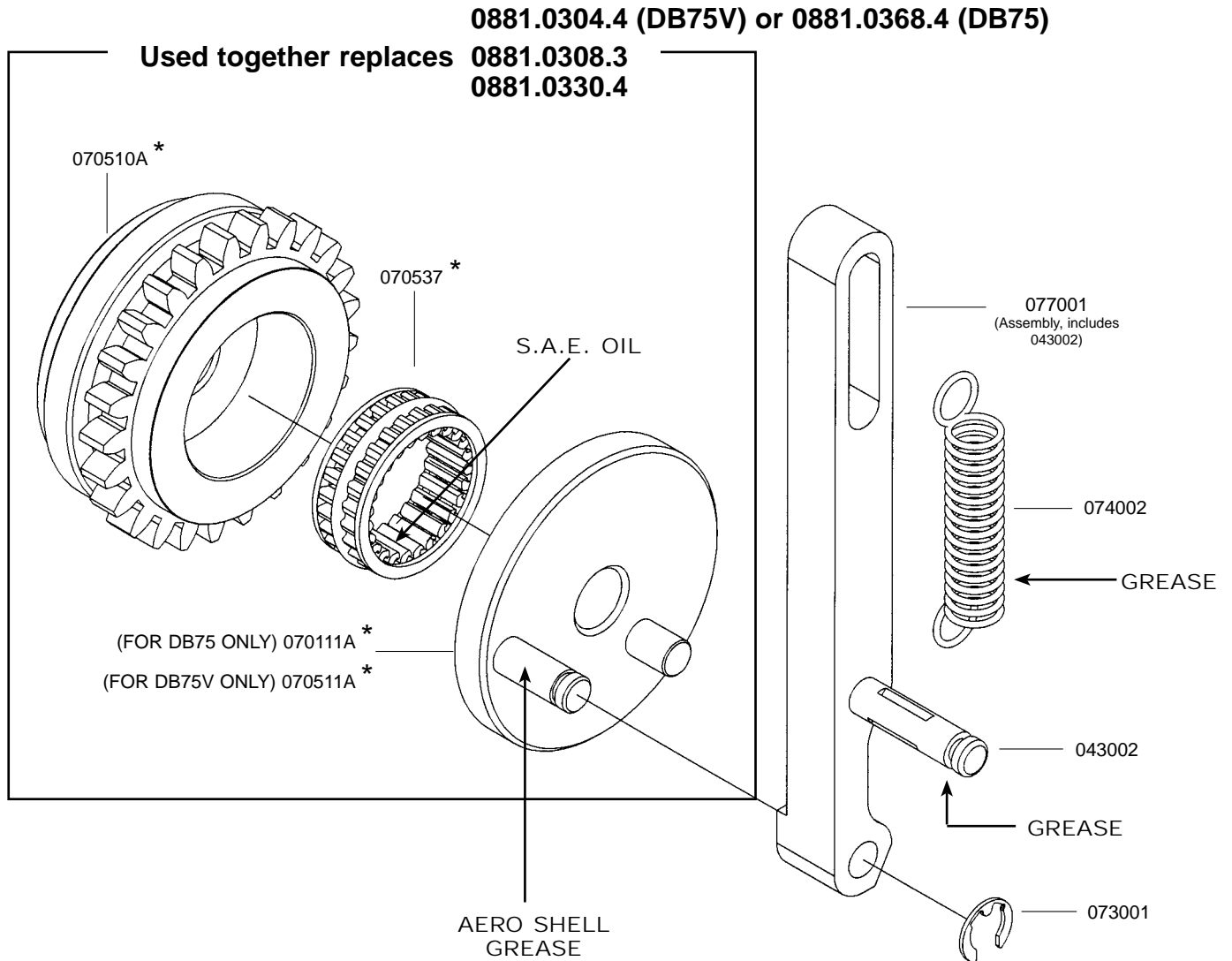

* Indicates parts that are not interchangeable with Müller-Martini parts.
All parts used together can be used interchangeably with the HK75 or HK75V.

Wire Holder Assemblies

DB75 & DB75V

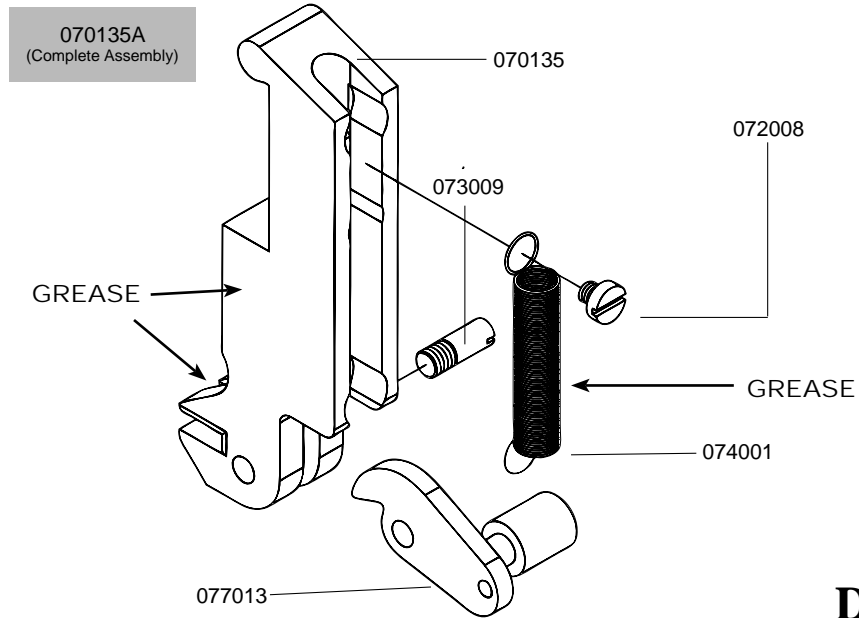

DB75VS

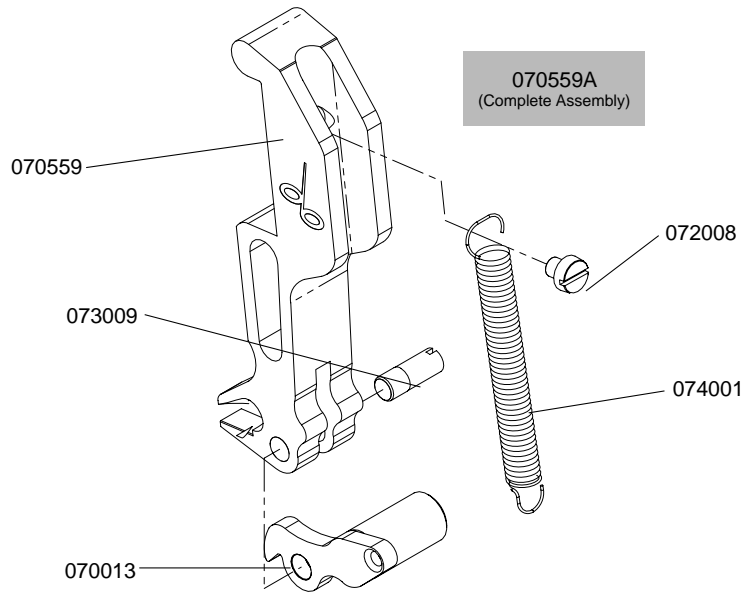

SHADED PART NUMBERS DENOTES WEAR PARTS

Clincher Plate Assemblies

SHADED PART NUMBERS DENOTES WEAR PARTS

077030 or 077030C (Carbide)

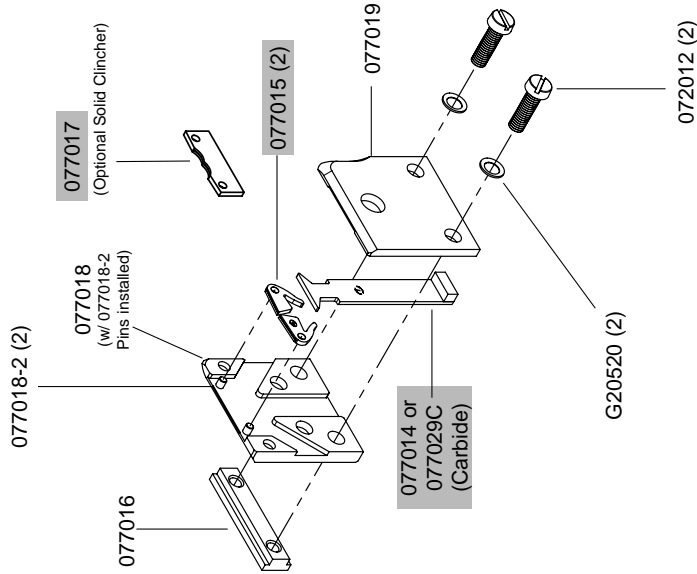

Standard Clincher Plate

070830A

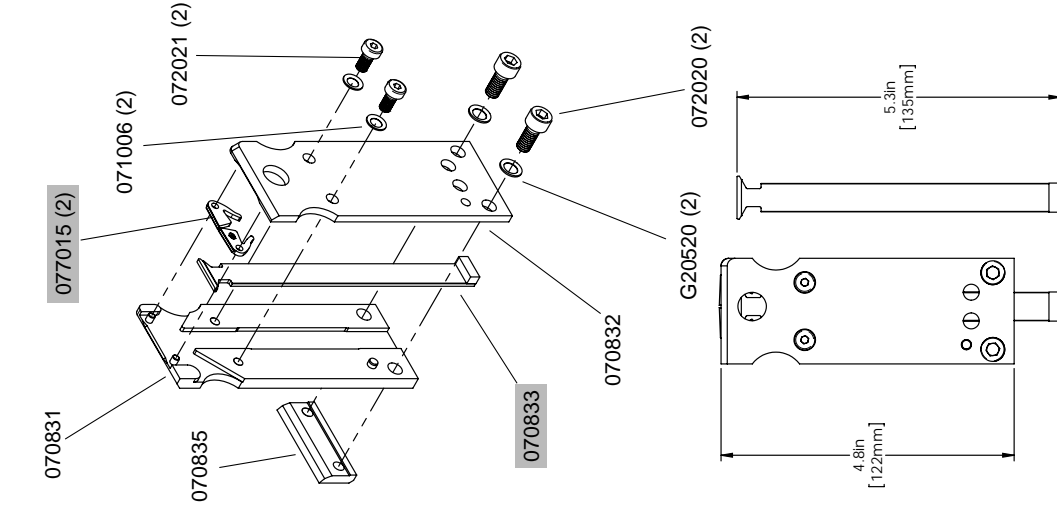

Used on Bravo/Prima machines
After 2004, used on all Optima & Supra machines

070850A

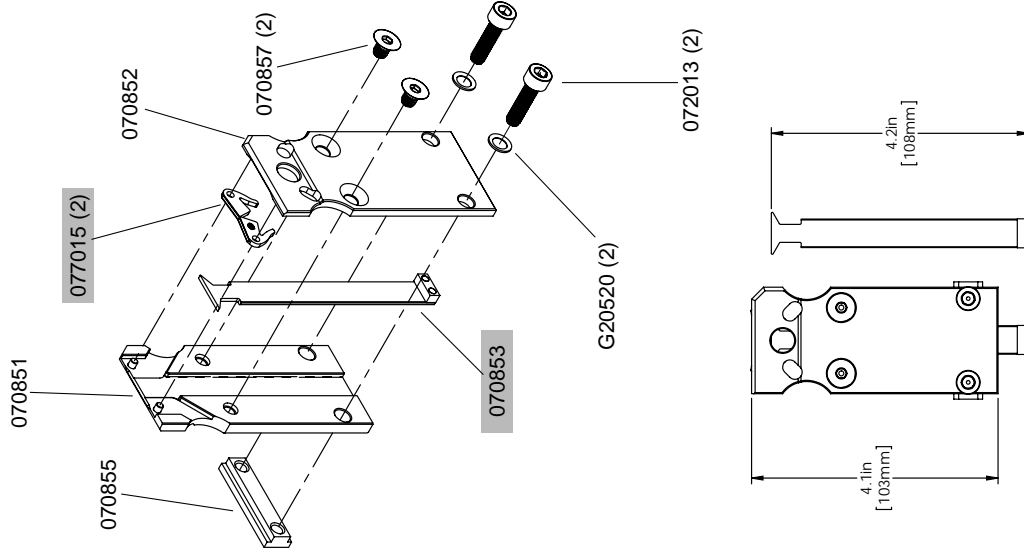

Used on all Presto & Valore machines
Used on Minuteman (1509) machines built after Jan. 2004

DeLuxe Stitcher / Müller Part Number Cross-Reference

043002	0031.6491	Grooved Pin	070552-23	0881.0367.3	Driver 22-24 Wire
044002	0354.1041.4	Feed Cam Compression Spring	070552-25	0881.0326.3	Driver 25-28 Wire
070000	0881.004.1	Bonnet - DB75	070554	0881.0312.4	Supporter
070111A	0881.0368.4DB	Feed Gear Pinion Assembly	070559A	0881.4112.3	Wire Holder Assembly, DB75VS
070112	0881.0003.4	Feed Gear, Small	070562A	0881.0309.4	Bender Slide Assembly
070114	0881.0008.4	Feed Gear Shaft	070583	0881.0321.4	Wire Holder Retaining Spring
070118	0881.0018.4	Feed Release Cam Assembly	070597A	0881.322.4	Cutter Box Assembly
070119	0022.0270	Feed Release Handle	070598	0249.1073.4	Cutter Operating Slide
070135A	0881.0058.3	Wire Holder Assembly	070600C	0881.0198.4	Fixed Cutter - Carbide
070144	0881.0042.4	Wire Tube	070830A		Clincher Plate Assy., Carbide
070145C	0881.0197.4	Moving Cutter - Carbide	070831		Clincher Back Plate, Bravo
070151A	0881.0051.4	Driver Slide Assembly	070832		Clincher Front Plate, Bravo
070152-20	0881.0153.4	Driver 20-24 Wire	070833		Clincher Slide, Carbide, Bravo
070152-23	0211.0039.3	Driver 22-24 Wire	070835		Clincher Mounting Bar, Bravo
070152-25	0881.0014.3	Driver 25-28 Wire	070850A		Clincher Plate Assy., Presto
070162A	0881.0050.4	Bender Slide Assembly	070851		Clincher Back Plate, Presto
070181	0881.0009.4	Upper Wire Tube	070852		Clincher Front Plate, Presto
070183	0034.6302	Wire Holder Retaining Spring	070853		Clincher Slide Assy., Presto
070186	0034.6301	Friction Strip	070855		Clincher Mounting Bar, Presto
070197A	0881.0010.4	Cutter Box Assembly	070857		Screw, M6x1.0x8, FHM
070198	0881.0007.4	Cutter Operating Slide	070001	0022.0042	Washer, Large
070206A	0249.1074.4	Wire Straightener Assembly	071002	0023.0931	Washer, Shim
070210	0034.2252	Cutter Box Spring	071004	0031.5103	Lock Washer, Ribbed
070230	0881.0006.4	Cutter Operating Lever	071005	0031.5104	Lock Washer Ribbed, 4mm
070244	0881.0043.4	Wire Tube Clamp	071006	0031.5105	Lock Washer, Ribbed
070286	0881.0301.3	Wire Guide Spring	071007	0031.9051	Lock Washer Ribbed, 3.5mm
070344	0881.0313.4	Supporter Spring	071008	0881.0323.4	Washer
070500	0881.0300.2	Bonnet - DB75V	072001	0030.0016	Screw M4x0.7x8
070510A	0881.0308.3DB	Feed Gear, Large	072003	0030.0018	Screw M4x0.7x12
070511A	0881.0304.4DB	Feed Gear Pinion Assembly	072004	0030.0048	Screw M6x1.0x12
070537	0881.0330.4DB	Feed Gear Clutch	072005	0030.0051	Screw M6x1.0x25
070544	0249.1014.4	Lower Wire Tube	072006	0030.0052	Screw M6x1.0x30
070548L-20	0881.0152.4	Former LH 20-24 Wire	072007	0030.1711	Screw M5x0.8x4
070548L-23	0881.0184.4	Former LH 22-24 Wire	072008	0030.3429	Screw M3x0.5x3
070548L-25	0881.0016.4	Former LH 25-28 Wire	072009	0030.3434	Screw M3x.5x10
070550R-20	0881.0151.4	Former RH 20-24 Wire	072010	0030.3447	Screw M4x0.7x5
070550R-23	0881.0185.4	Former RH 22-24 Wire	072011	0030.3451	Screw M4x0.7x12
070550R-25	0881.0015.4	Former RH 25-28 Wire	072012	0030.3488	Screw M6x1.0x20
070551A	0249.1065.4	Driver Slide Assembly	072013	0030.9001	Screw M6x1.0x22
070552-20	0881.0319.3	Driver 20-24 Wire	072014	0030.9016	Screw M4x0.7x12 LH

DeLuxe Stitcher / Müller Part Number Cross-Reference

072015	0249.1054.4	Driver Retaining Screw	077024	0881.0317.4	Hook Guide, DB75V
072016	0881.0039.4	Screw M4x0.7x18	077025	0881.0320.4	Wire Holder Guide
072017	0881.0041.4	Screw M5x0.8x5.5	077026	0881.0324.4	Feed Gear Stop
072018	0881.0045.4	Screw M4x0.7x6	077027B	0881.0325.4	Mounting Strap, DB75V
072019	0881.0318.4	Screw M4x0.7x16	077029C	0881.0351.3	Clincher Slide - Carbide
072020		Screw, M6x1.0x14, SHC	077030	0881.9050	Clincher Plate Assy
072021		Screw, M5x0.8x10, SHC Low	077030C	0881.9050CAR	Clincher Plate Assy-Carbide
073001	0031.0757	E-Ring	078001	0881.0374.4	Bearing, Mount Shaft
073002	0031.0759	E-Ring	078002	0038.1243	Bearing, Bender/Driver Bar
073003	0031.5021	Cotter Pin	078003	0038.3610	Bearing, Small Gear
073004	0031.6039	Spring Pin, M5x12	078005	0209.2367.4	Shim Washer
073005	0031.6310	Spring Pin, M3x10	078006	0023.0955	Shim Washer
073006	0031.6212	Spring Pin, M3x12	078008	0023.0957	Shim Washer
073007	0031.6316	Spring Pin, M3x16	078010	0881.0366.4	Feed Cam Plunger Bushing
073009	0881.0027.4	Hook Pivot Pin, Nylon	078012C	0881.0371.4	Bender Slide Insert-Carbide
073010	0881.0030.4	Dowel Pin, M6x32	078024	0881.4005.4	Hook Guide
073012	0881.0314.4	Dowel Pin, M6x55	078112A	0881.0364.4	Small Feed Gear Asy (Combine)
074001	0034.0102	Extension Spring	"	0038.3610	Small Gear Bearing (Combine)
074002	0034.0302	Extension Spring	078118A	0881.0363.3	Feed Release Cam Assembly
074003	0034.2152	Center Guide Spring	078230C	0881.0370.4	Cutter Operating Lever-Carbide
074004	0034.2370	Compression Spring	078551A	0881.0336.3	Driver Slide Assembly
077001	0881.001.4	Feed Gear Operating Lever Assy	078562A	0354.1036.3	Bender Slide Assembly
077002	0881.0013.4	Centering Guide Post	G20195	0030.1725	Screw M6x1x8
077003	0881.0017.4	Centering Guide	G20229	0030.1727	Screw M6x1x12
077006B	0881.0021.4	Mounting Strap	G20287	0034.2254	Wire Oiler Felt Spring
077007	0881.0022.4	Set Collar	G20292	0881.0302.4	Wire Oil Felt Washer
077009	0881.0032.4	Feed Cam Plunger	G20293	0881.0303.4	Wire Oiler Felt
077010	0881.0035.4	Feed Cam Plunger Bushing	G20297	0030.3494	Screw M6x1x40
077011	0881.0037.4	Hook Guide, DB75	G20298	0030.3494	Hex Nut M6x1
077014	0881.0123.4	Clincher Slide Assembly	G20360		Hex Key Wrench 3.0mm
077015	0881.0125.3	Clincher Point 1/2"	G20361		Hex Key Wrench 2.5mm
077016	0881.0136.4	Clincher Mounting Bar	G20362		Clamp Wrench 5.0mm
077017		Solid Clincher	G20373		Hex Key Wrench 4.0mm
077018	0881.0141.3	Clincher Back Plate	G20520	0031.0557	Lock Washer Ribbed, 6mm
077019	0881.0142.3	Clincher Front Plate	G20589	0030.0017	Screw M4x0.7x10
077021	0881.0311.4	Supporter Block	MMKFG1	(See page 28)	Müller Feed Gear Kit
077022	0881.0315.4	Centering Guide, Wide	MMKFG2	(See page 28)	Müller Feed Gear Kit
077023	0881.0316.4	Centering Guide, Narrow			

REGISTRATION

To better service your wire stitching needs, please take a moment to fill out and return this registration card.

Please take a moment to fill out the attached card and mail it to DeLuxe Stitcher Company, Inc.. In addition, duplicate the information for your records to assist when making further inquiries.

CUSTOMER

Name : _____
(First) _____ (Middle Initial) _____ (Last)
Company : _____
Street Address : _____
City : _____ State/Province : _____ Zip : _____
Country : _____
Phone : _____ Fax : _____ E-mail : _____

PRODUCT

Machine(s) Purchased : _____
Serial Number(s) : _____
With Head(s) : _____
(Type/Quantity Purchased)
Serial Number(s) : _____
Head(s) Purchased : _____
Serial Number(s) : _____

DEALER

Date Received : _____
Dealer Name : _____
Dealer Street Address : _____
City : _____ State/Province : _____ Zip : _____
Country : _____
Dealer Phone : _____

Other Bindery Products Used : _____

PRODUCT

Machine(s) Purchased : _____
Serial Number(s) : _____
With Head(s) : _____
(Type/Quantity Purchased)
Serial Number(s) : _____
Head(s) Purchased : _____
Serial Number(s) : _____

DELUXE STITCHER GRAPHIC ARTS REPRESENTATIVE

Date Received : _____
Dealer Name : _____
Dealer Street Address : _____
City : _____ State/Province : _____ Zip : _____
Country : _____
Dealer Phone : _____

Would you like information sent to you about new products that would benefit your company? Yes No

Common Replacement Parts for 1/2" Crown

Below is a list of the most common wear/replacement parts for the DB75 and 75V Stitcher Head. This guide should help you when ordering replacement parts. If the part you need is not listed below, please refer to the more detailed parts list on pages 47 - 48.

Description	Item Number
Moving Cutter - Carbide	070145C
Driver (DB75) - 25-28	070152-25 or 070552-25
Wire Holder Retaining Spring	070183
Cutter Operating Lever	070230
Fixed Cutter - Carbide	070600C
Moving Cutter Screw	072014
Screw, M4x0.7x6-Nylon	072018
Rivet	073008
Hook Pivot Pin, Nylon	073009
Wire Holder Spring	074001
Hook Guide	077011
Bender Slide Insert	077012
Clincher Slide Assembly	077014
Clincher Point 1/2"	077015
Clincher Point Pivot	077018-2

PLACE
STAMP
HERE

DELUXE STITCHER
COMPANY, INC.
6635 West Irving Park Road
Chicago, Illinois 60634-2410 U.S.A.
Attn: Customer Service

LIMITED WARRANTY

DeLuxe Stitcher Company, Inc. warrants to the original retail purchaser that this product is free from defects in material and workmanship and agrees to repair or replace, at DeLuxe Stitcher's option, any defective product within 90 days from the date of purchase. This warranty is not transferable. It covers damage resulting only from defects in material or workmanship and does not cover conditions or malfunctions resulting from normal wear, neglect, abuse or accident.

This warranty is in lieu of all other express warranties. Any warranty of merchantability or fitness for a particular purpose is limited to the duration of this warranty. DeLuxe Stitcher shall not be liable for any incidental or consequential damages.

Some states do not allow limitations on how long an implied warranty lasts, or the exclusion or limitation of incidental or consequential damages, so the above limitations or exclusions may not apply to you. This warranty gives you specific legal rights and you may also have other rights which vary from state to state.

To obtain warranty service you must return the product, at your expense, together with proof of purchase to an authorized DeLuxe Stitcher Company Graphic Arts Dealer.

Always use genuine DeLuxe Stitcher parts. When ordering parts, please identify the part number, the part name, the wire size and crown size of your Stitcher.

DeLuxe Stitcher Company, Inc.
6635 West Irving Park Road
Chicago, Illinois 60634-2410
Phone: 773-777-6500 800-634-0810
Fax: 773-777-0156 800-417-9251
E-mail: info@deluxestitcher.com
Web Site: <http://www.deluxestitcher.com>

NOTES

