

hohner

M 45/6

Edition 08/2006

Stitching Head

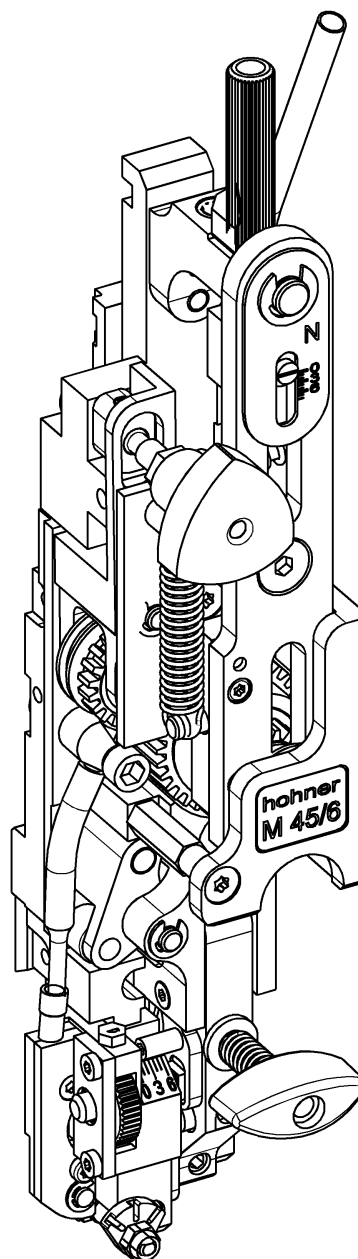

CE

Customer Entries

Stitching head no:

Machine manufacturer:

Type of manufacturer:

Manufacturer' s Address

Company name: **hohner** Maschinenbau GmbH

Street: Gänsäcker 19

Town: D-78532 Tuttlingen

Telephone: +49 7462 / 9468-0

Fax: +49 7462 / 9468-20

Email: info@hohner-gmbh.de

Internet: <http://www.hohnerstitching.com>

Spare Parts / Customer Service

Service telephone no: +49 7462 / 9468-23

List of Contents

1	SAFETY INFORMATION	6
1.1	Purpose of this document	6
1.2	The operator	6
1.3	Safety symbols and the displays that have been used	6
1.4	Obligation and liability	7
1.5	Correct use	7
1.6	Organisational measures	7
1.7	Safety and protective devices	7
1.8	Non-formal safety measures	7
1.9	Staff training	7
1.10	Parts of the equipment which are particularly dangerous	8
1.11	Maintenance and repair work, elimination of faults	8
1.12	Structural modifications to the stitching head	8
1.13	Cleaning the machine and the disposal of waste products	8
2	DESCRIPTION OF THE STITCHING HEAD	9
2.1	General overview	10
2.2	Conformity	10
2.3	Marking and type plate	10
2.4	Technical data	10
2.4.1	Normal stitch	11
2.5	Dimensional sheet	13
2.6	Outfitting of the stitching head	13
2.6.1	Basic features	13
2.6.2	Additional equipment	13
3	OPERATION	14
3.1	Installation of the stitching head	15
3.1.1	Clamping the stitching head	15
3.1.1.1	Lateral adjustment of the stitching head	15
3.1.2	Fitting the wire guide	17
3.1.3	Fitting the clincher box	19
3.1.4	Adjusting the clincher box	21
3.2	Feeding the stitching wire	23
3.3	Removing the stitching wire	23
3.4	Removing the wire guidance sleeves in the event of a stitching wire jam	23
3.5	Straighten the stitching wire	25
3.6	Setting the stitch length	27
3.6.1	Basic setting of the stitch length	27
3.6.2	Fine adjustment of the stitch length	27
3.6.3	Setting the leg length of the stitch	29
3.7	Setting the former	31
3.8	Spine centering parts	33
3.8.1	Installing the holding down device (standard version)	33
3.8.2	Adjusting the holding down device (standard version)	33
3.8.3	Installing the holding down device (optional narrow version)	33
3.8.4	Adjusting the holding down device (optional narrow version)	33
4	SERVICING	34
4.1	Lubrication	35
4.1.1	Lubricants	35
4.1.2	Lubrication plan	35
4.2	Installation and replacement of parts	36
4.2.1	Replacing the former	37
4.2.2	Removing the bender stop	39
4.2.3	Replacing the bender	39
4.2.4	Replacing the knife	41
4.2.4.1	Rotating/Changing the flat knife	41

4.2.4.2	Replacing the circular knife	41
4.2.4.3	Adjusting the circular knife	41
4.2.5	Replacing the driver	43
5	FAULTS	44
5.1	Causes and elimination of faults	44
	SPARE PARTS LIST	E1

1 Safety Information

1.1 Purpose of this document

This document will inform the operator of the **Stitching Head M 45/6** of the following:

- The safety symbols and signs
- The packing of the machine and its transportation
- The function and operation of the machine
- Commissioning the machine
- The elimination of faults which arise
- Servicing

Familiarity with this Operating Manual is thus a prerequisite for the safe and correct operation of the stitching head. It must be read carefully by the operator before the machine is commissioned. Keep the manual safely in a place where it is readily available and which is close to hand for persons working on the machine.

1.2 The operator

The **Stitching Head M 45/6** must only be operated by trained personnel.

Training will be undertaken by the manufacturer or by persons who have been authorised by the manufacturer to undertake such training.

1.3 Safety symbols and the displays that have been used



This symbol indicates immediate danger to the life or health of persons in the immediate vicinity of the machine.

Non-observance of dangers which are so indicated can have grave consequences and can cause serious damage to health, or may even to lead to deaths.



This symbol indicates that a potentially dangerous situation has arisen.

Non-observance of dangers which are so indicated can lead to slight injuries to persons or damage to equipment.



TIP

This symbol indicates that tips on how to use the machine or particularly useful information are available.

These will help you to use all of the functions of the machine in an optimal manner.

- ***This symbol requires you to take action.***
- ***This sign serves as a symbol for listing items.***

1.4 Obligation and liability

The **Stitching Head M 45/6** has been built according to state-of-the art technology under observance of all the recognised safety regulations. However, dangers to life and limb of the user or third parties and damage to the system or other material assets can still occur during use. The stitching head should only be used,

- for the purpose for which it was designed
- when it is in a perfect technical condition.

Faults which could reduce levels of safety when using the machine must be eliminated immediately.

Warranties and liability on the part of the manufacturer are fundamentally covered by the regulations laid down in our "General sales and delivery conditions".

Warranty claims will only be valid if the number label is affixed (number label on stitching head housing).

1.5 Correct use

The **Stitching Head M 45/6** is designed exclusively for binding brochures and leaflets or similar items.

Any use of the machine contrary to that described above is forbidden, since incorrect use of the machine can present a danger.

1.6 Organisational measures

The user of machine is required to provide the required personal safety equipment. All existing safety devices should be checked regularly.

1.7 Safety and protective devices

All safety and protective devices must be correctly attached to the machine and should be in full working order before every start-up of the machine and **Stitching Head M 45/6**.

Safety and protective devices may only be removed:

- After the machine has come to a standstill **and**
- As security against the machine starting up again.

1.8 Non-formal safety measures

The Operating Manual must be kept so that it is permanently at hand at the machine with **Stitching Head M 45/6**. There are also generally valid local regulations concerning accident prevention and environmental protection measures which should be made available and observed in addition to those described in the Operating Instructions.

All safety and danger signs on the machine should be maintained in a legible condition and should be renewed where necessary.

1.9 Staff training

Only trained and instructed personnel may install, operate, set and maintain the stitching head.

Safety Information

1.10 Parts of the equipment which are particularly dangerous

There is a **risk of injury** in the area of moving parts of the stitching head.



1.11 Maintenance and repair work, elimination of faults

Undertake the required setting, servicing and inspection work on schedule.

The machine may only be operated in cycle mode during all servicing, inspection and repair work on the **Stitching Head M 45/6**.

Always make absolutely sure **that the machine is only being operated by one person in order to avoid any influence to the machine by any other persons.**



1.12 Structural modifications to the stitching head

Changes to the stitching head, additions or modifications may only be undertaken with the manufacturer's permission.

1.13 Cleaning the machine and the disposal of waste products

The functionality of the stitching head and perfect processing of the product can only be guaranteed over a prolonged period of time if the stitching head is regularly cleaned and maintained in accordance with the standard methods of mechanical engineering.

In this regard, particular attention should be paid to the regular removal of trimmed paper residue and paper dust, as these can result in jamming of the stitching head or increased wear.



Substances and materials used (e.g. solvents and lubricants) must be handled correctly and disposed of in an environmentally friendly manner.

2 Description of the Stitching Head

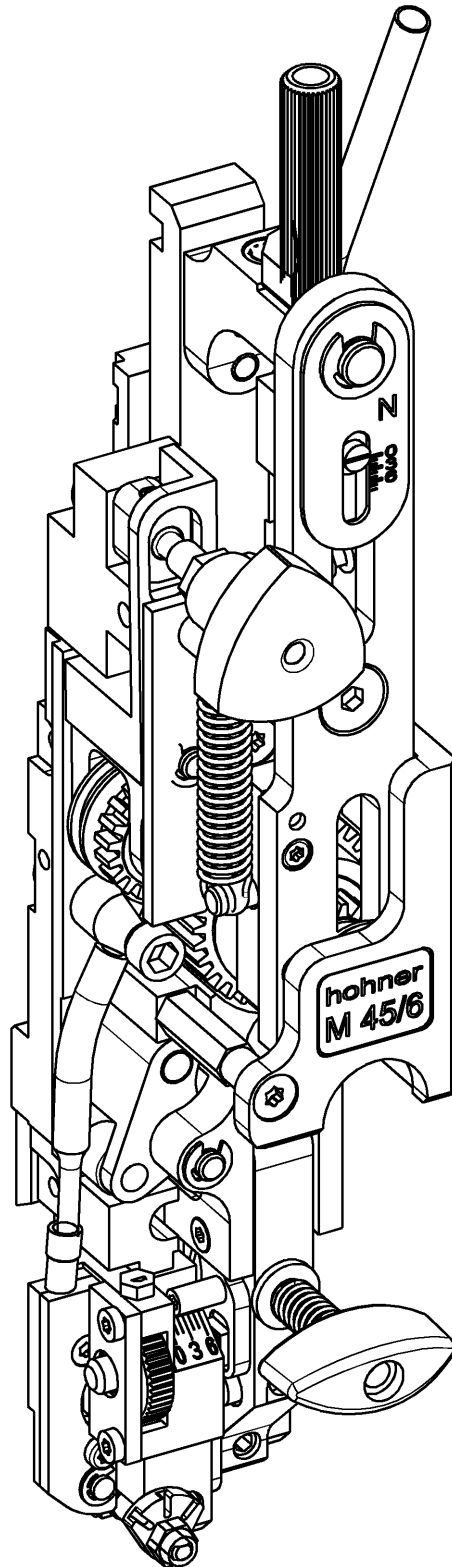

Fig. 1

Description of the Stitching Head

2.1 General overview

- Fig. 1 -

2.2 Conformity

The **Stitching Head M 45/6** conforms to the following guidelines and standards:

- Machine Guideline (98/37/EEC)
- EN 1010-1:1998 (final draft version) and EN 1010-4:1997 "Machine safety – safety requirements in connection with the design and manufacture of printing and paper processing machines", "Part 1: General requirements" and "Part 4: Bookbinding, paper processing and paper finishing machines".
- This Operating Manual takes account of DIN EN 292, machine safety, basic terminology, general principles of design.



2.3 Marking and type plate

The type plate is located at the front of the stitching head.

The stitching head serial number is located on an adhesive plate on the right side of the housing.

2.4 Technical data

Net weight of the stitching head	1.8 kg / 3.97 lbs
Quality of the stitching wire	Only use perfect quality classes, in normal or steel strength as required. Pay attention to abrasion resistance, as heavy abrasion will clog the wire-guidance parts.

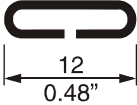
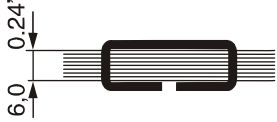
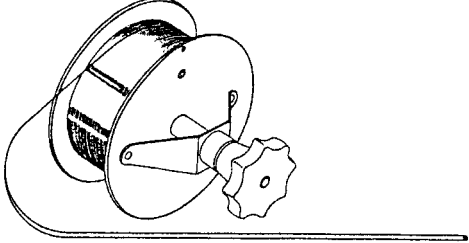
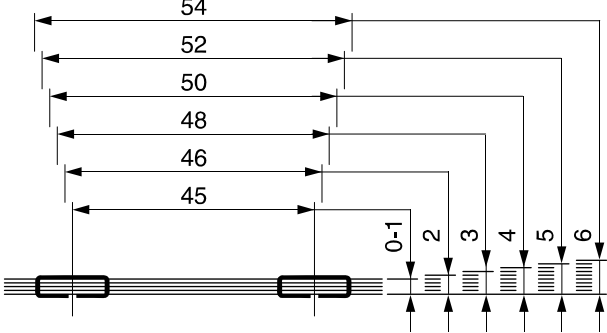
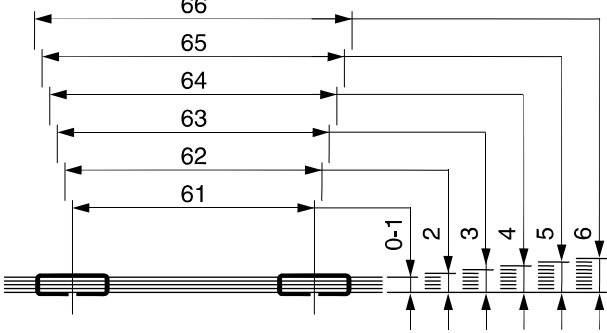
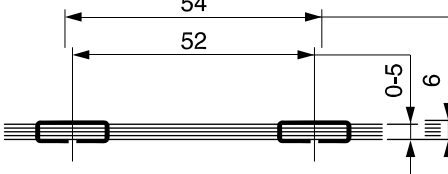

2.4.1 Normal stitch

<p>Wire stitch dimensions</p>	
<p>Max. stitch thickness</p>	
<p>Round stitching wire No. 24 - 26 Ø 0.60 - 0.50 mm (Ø 0.024 - 0.020 in.)</p> <p>or:</p> <p>Round stitching wire No. 26 - 28 Ø 0.50 - 0.40 mm (Ø 0.020 - 0.016 in.)</p> <p>or:</p> <p>Round stitching wire No. 23 Ø 0.70 mm (Ø 0.027 in.)</p>	
<p>Possible distances between wire stitches and stitch thicknesses in mm</p>	
<p>With holding down device - standard -</p>	
<p>Optional: with holding down device, left</p>	

Description of the Stitching Head

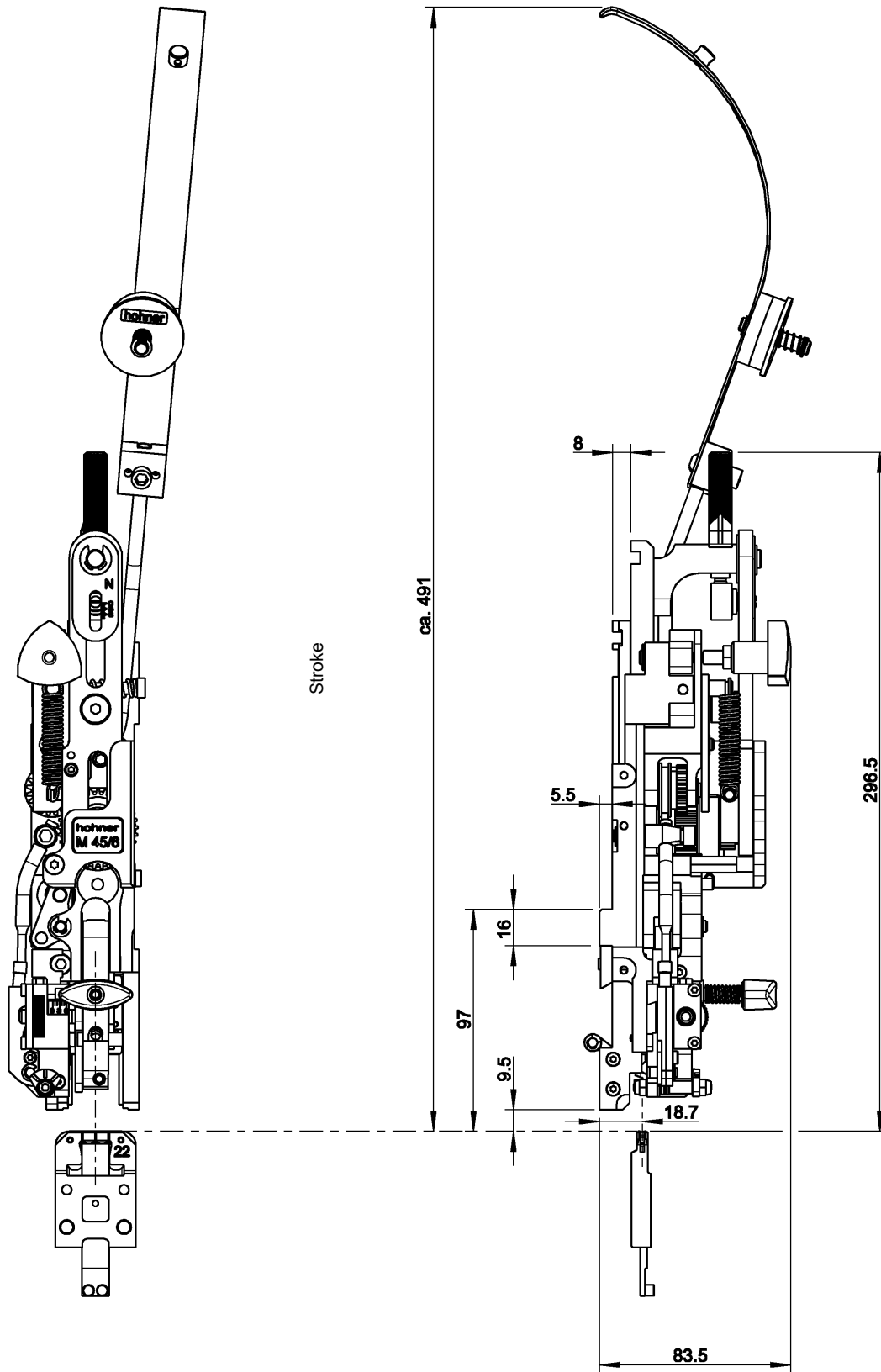

Fig. 2

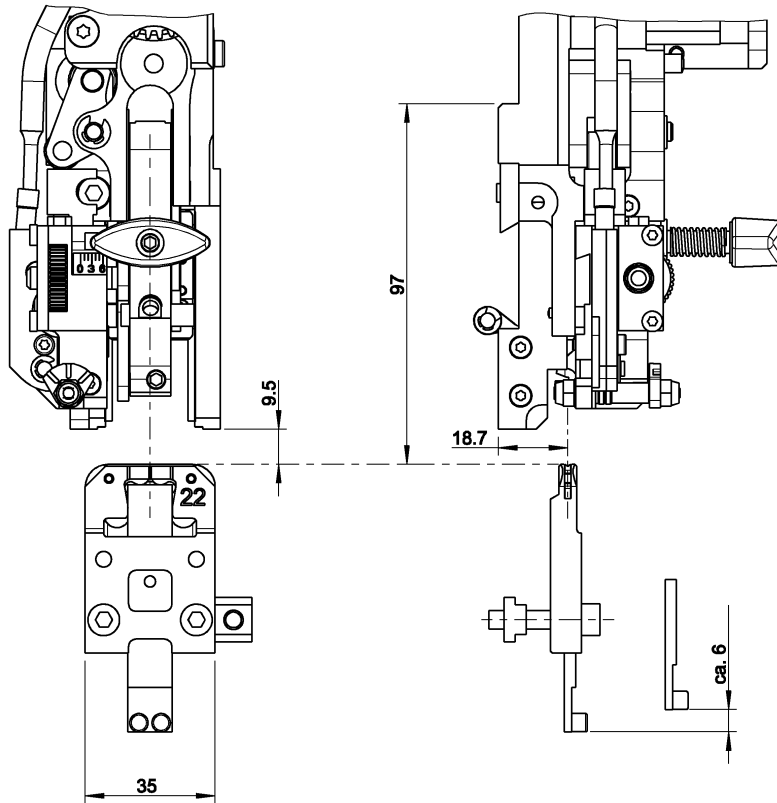

Fig. 3

2.5 Dimensional sheet

- Fig. 2 , Fig. 3-

2.6 Outfitting of the stitching head

2.6.1 Basic features

The stitching head is delivered with the following accessories:

DESCRIPTION	ORDER NUMBER
Clincher box adjustment gauge	31 64 448
Hexagon key SW 3	46 00 008
Allen key with T-handle SW4 x 150	46 00 033
Torx screwdriver T7	46 00 036
Torx screwdriver T10	46 00 044
Torx screwdriver T20	46 00 045
Adjusting handle	94 55 096
Holding down set, complete	99 55 090
Wire clamp, complete	99 55 150
Clincher box, complete	Depending on machine type

2.6.2 Additional equipment

The following optional accessories are available:

DESCRIPTION	ORDER NUMBER
Tenon block strip for stitching head - distance 80	31 59 014
Clamping strip for clincher box - distance 80	31 59 414
Holding down set, left – narrow version	99 55 075
Set of interchangeable parts for round wire no. 23	99 55 323
Set of interchangeable parts 24 -26	99 55 324
Set of interchangeable parts 26 -28	99 55 326
Pan area	99 55 515

Operation

3 Operation

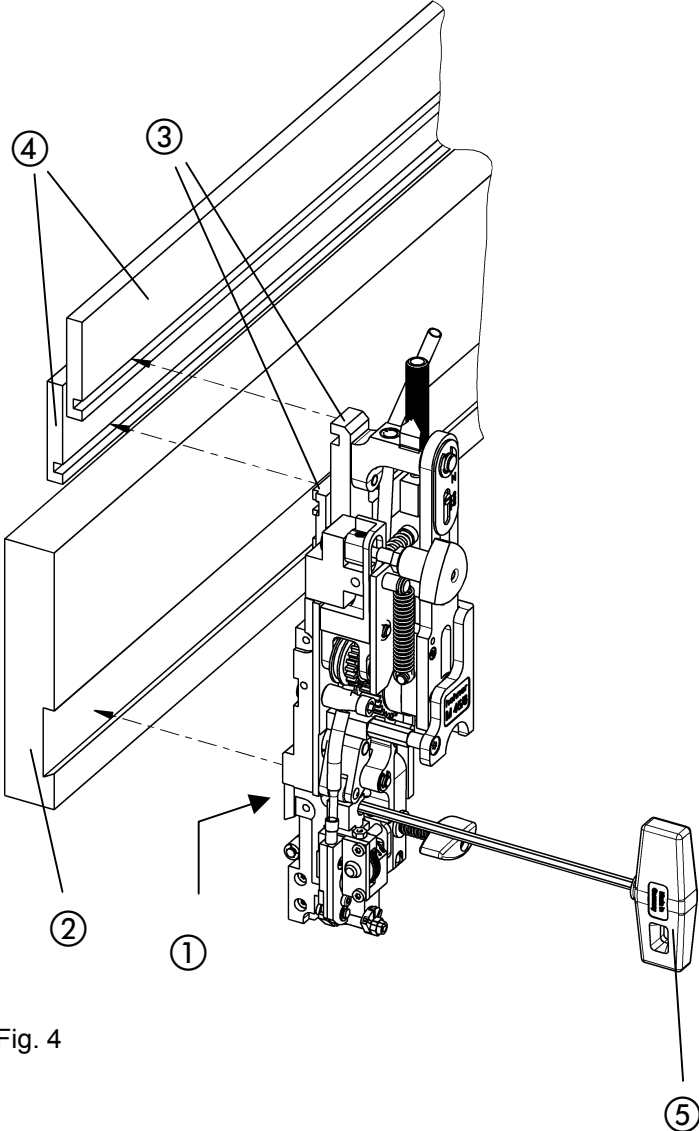

Fig. 4

3.1 Installation of the stitching head

3.1.1 Clamping the stitching head

- Fig. 4 -

The stitching head is held by a tenon block which is inserted into the stitching head mounting on the machine.

- Loosen tenon block ① with Allen key SW4 ⑤.
- Mount stitching head by laterally inserting the tenon block into the stitching head mounting ②.
The two driver lugs ③ on the stitching head must be located in the guides of the lifting bar.
- Fix stitching head in stitching head mounting by tightening the tenon block ① with the Allen key.

3.1.1.1 Lateral adjustment of the stitching head

- Fig. 4 -



The center of the wire formed parts within the stitching head must be set to the desired stitching position for the wire stitch by lateral adjustment.

- Loosen the tenon block ① with the Allen key ⑤.
- Move the stitching head sideways, until the desired position is reached.
- Fix the tenon block in the stitching head mounting ② with the Allen key.

Operation

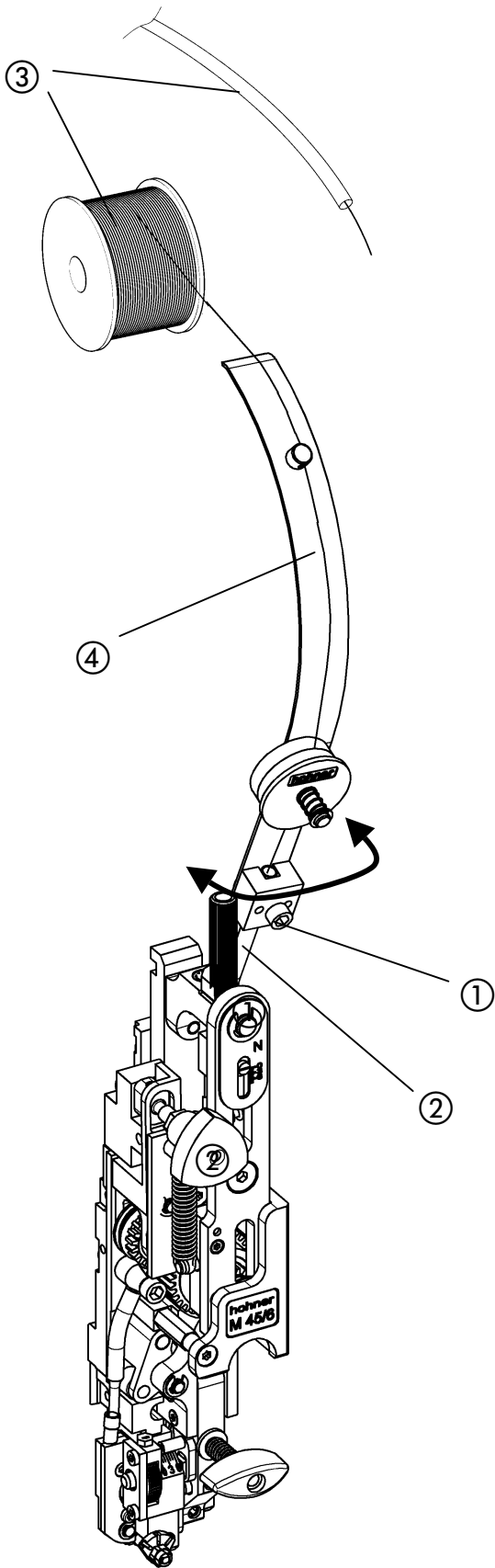

Fig. 5

3.1.2 Fitting the wire guide

- Fig. 5 -

- Loosen screw ① and place wire clamp ④ on wire guidance tube ②.
- Align wire clamp ④ with wire roller and wire feed tube ③, in order to ensure perfect wire guidance.
- Fix wire clamp ④ by tightening screw ①.

Operation

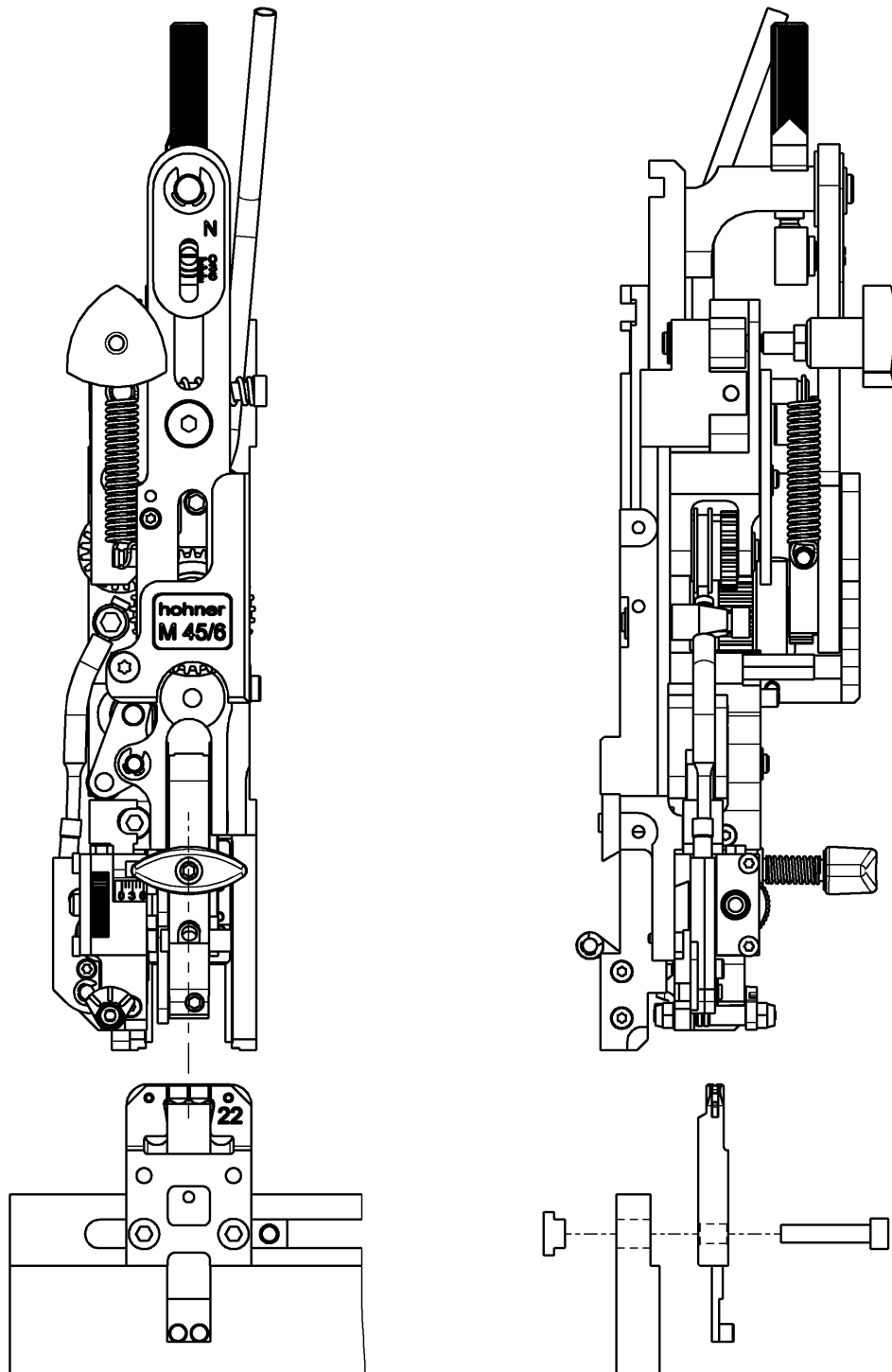

Fig. 6

3.1.3 Fitting the clincher box

- Fig. 6 -

The procedure for fitting the clincher box is described in the stitching unit instruction manual.

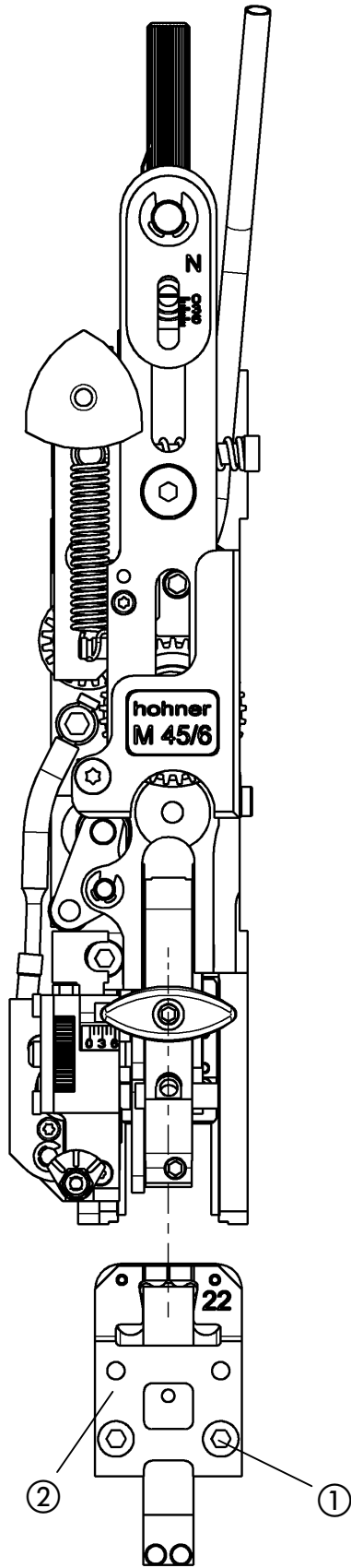

Fig. 7

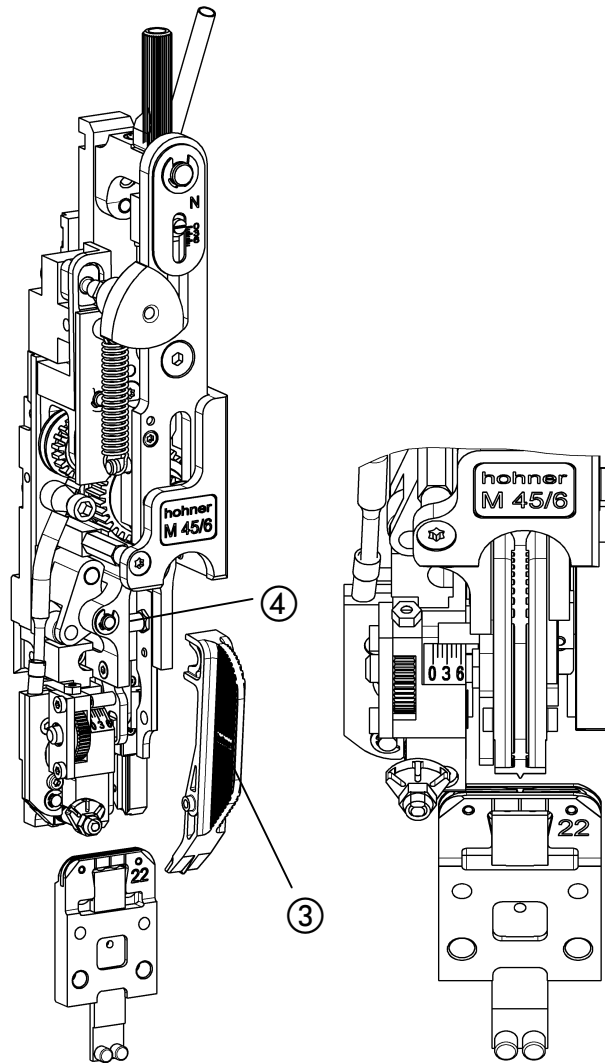

Fig. 8

3.1.4 Adjusting the clincher box

- Fig. 7 -

The center of the bender inside the stitching head must be precisely aligned with the center of the clincher box.

- Loosen clamping nuts ①.
- Move clincher box ② until it is precisely aligned with the center of the wire formed parts.
- Fix clincher box by tightening the clamping nuts.

Using the clincher box adjustment gauge

- Fig. 8 -

- Remove the former (see page 37). Place gauge ③ on former locating pin ④ and rotate downwards towards the stop. In this position the clincher box can be precisely adjusted by aligning the gauge with the scale marks on the clincher box.
- Tighten clamping nuts ① and remove gauge ③. Replace former.

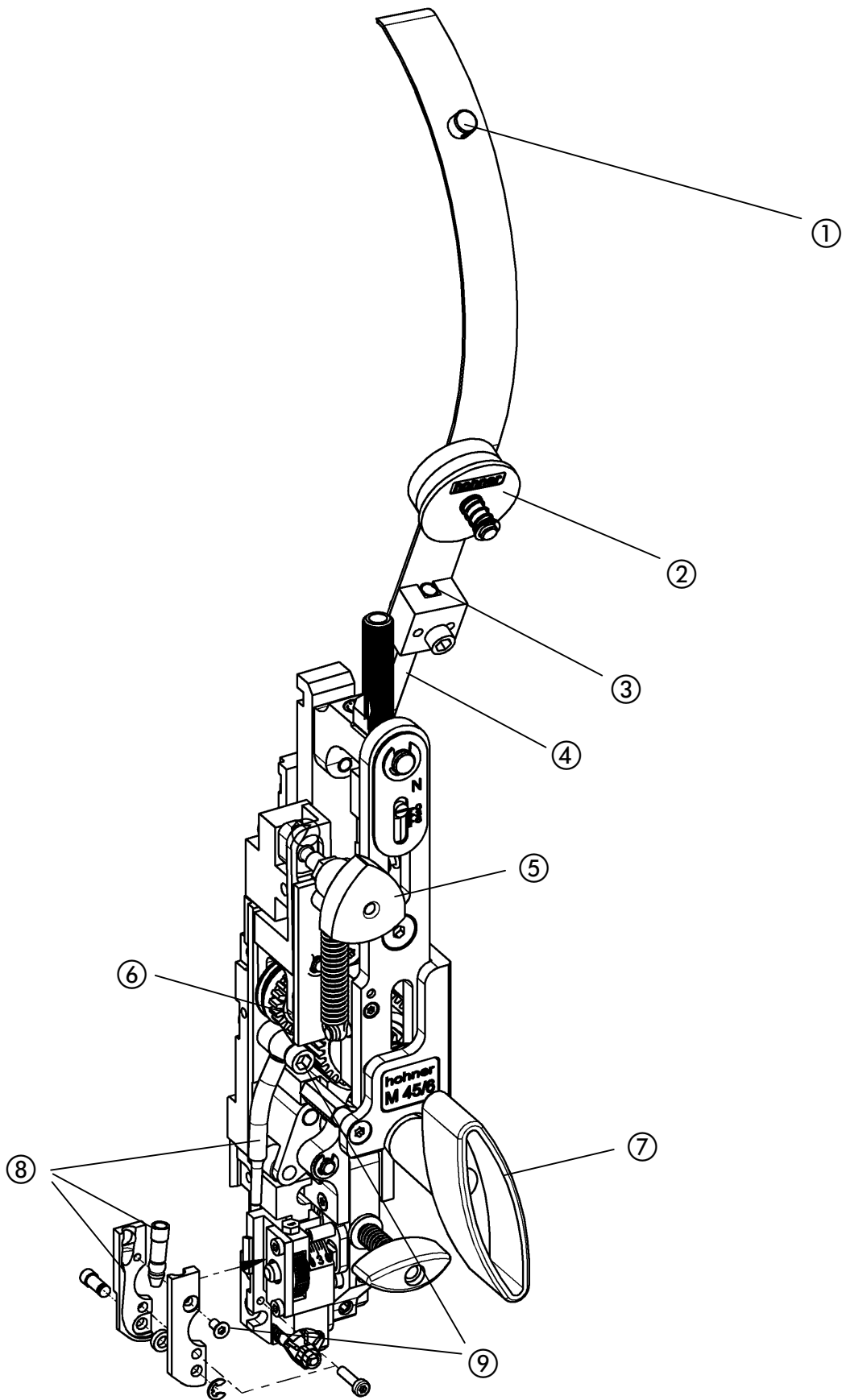

Fig. 9

3.2 Feeding the stitching wire

- Fig. 9 -

- Stop wire feed (move triangular handle ⑤ into "middle position").
- Push stitching wire through from above, as follows:
through the eye ① of the wire clamp – between the two felt disks ② into the hopper ③ – through the wire guidance tube ④ and between the two conveyor rollers ⑥.
- Restart the wire feed (turn triangular handle ⑤ to the left or right).
- Mount adjusting handle ⑦.
- Convey stitching wire by turning the adjusting handle ⑦ to the right as far as the knife.

3.3 Removing the stitching wire

- Fig. 9 -

- Stop wire feed (move triangular handle ⑤ into "middle position").
- Remove wire.

3.4 Removing the wire guidance sleeves in the event of a stitching wire jam

- Fig. 9 -

If a wire jam occurs in the area of the wire guidance sleeves, this will be easier to eliminate if you remove the wire guidance sleeves.

- Stop wire feed (move triangular handle ⑤ into "middle position").
- Loosen screw ⑨ and remove wire guidance sleeves ⑧
- Disentangle wire and remove from wire guidance sleeves.
- Remove wire.

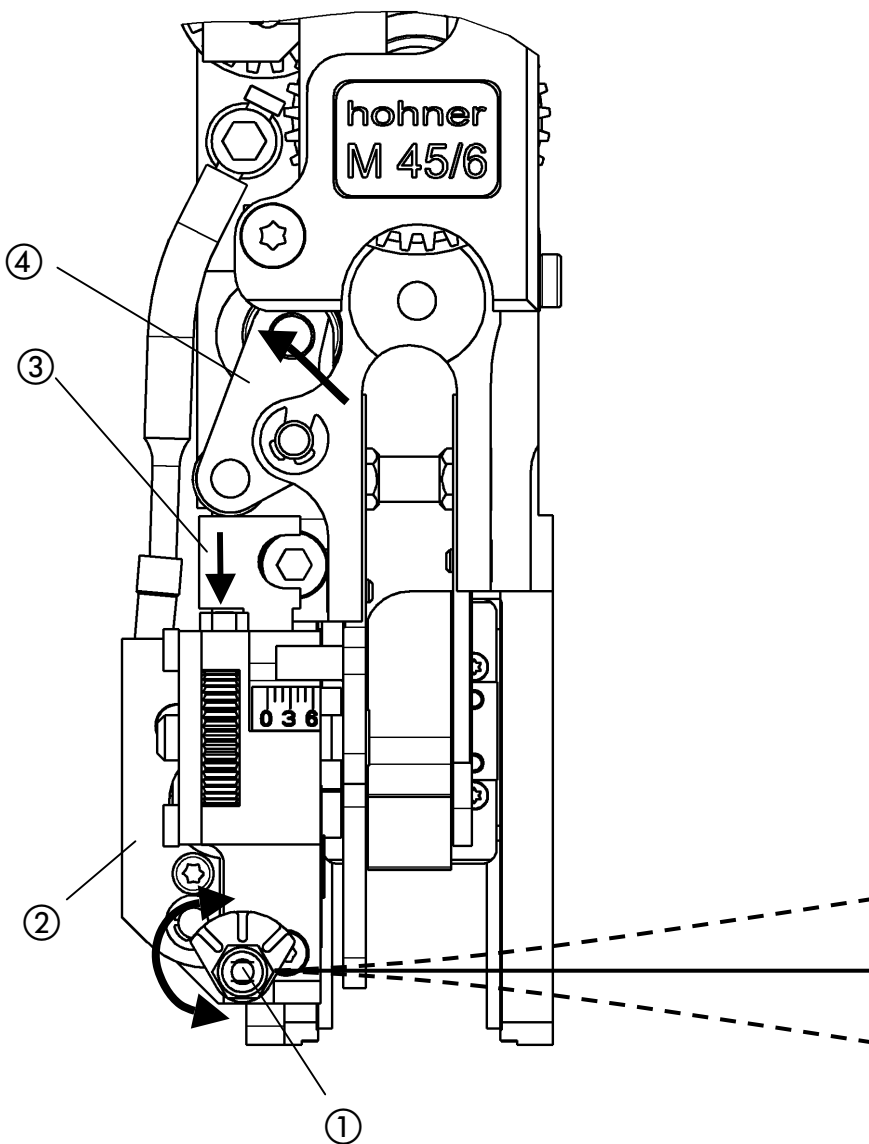

Fig. 10

3.5 Straighten the stitching wire

- Fig. 10 -

The stitching wire must run absolutely straight out of the circular knife. The wire feed can be set to run absolutely straight by turning the wire alignment roller ① which is arranged on eccentric bearings.

Wire straightening procedure:

- First remove former. (cf. 4.2.1)

a) Activate the machine's jog switch if possible.

b) Manual wire feed (cf. 3.2 Feeding the stitching wire)

Wire can be fed by turning the provided adjusting handle in the clockwise direction. When doing this, it is a good idea to cut off any overlong pieces of wire, by pressing down the knife slider ③.

(Made easier by levers on the cutting rocker ④)

- Turn eccentric fixing of the wire alignment roller ① with the screwdriver until the stitching wire runs absolutely straight out of the circular knife.

Operation

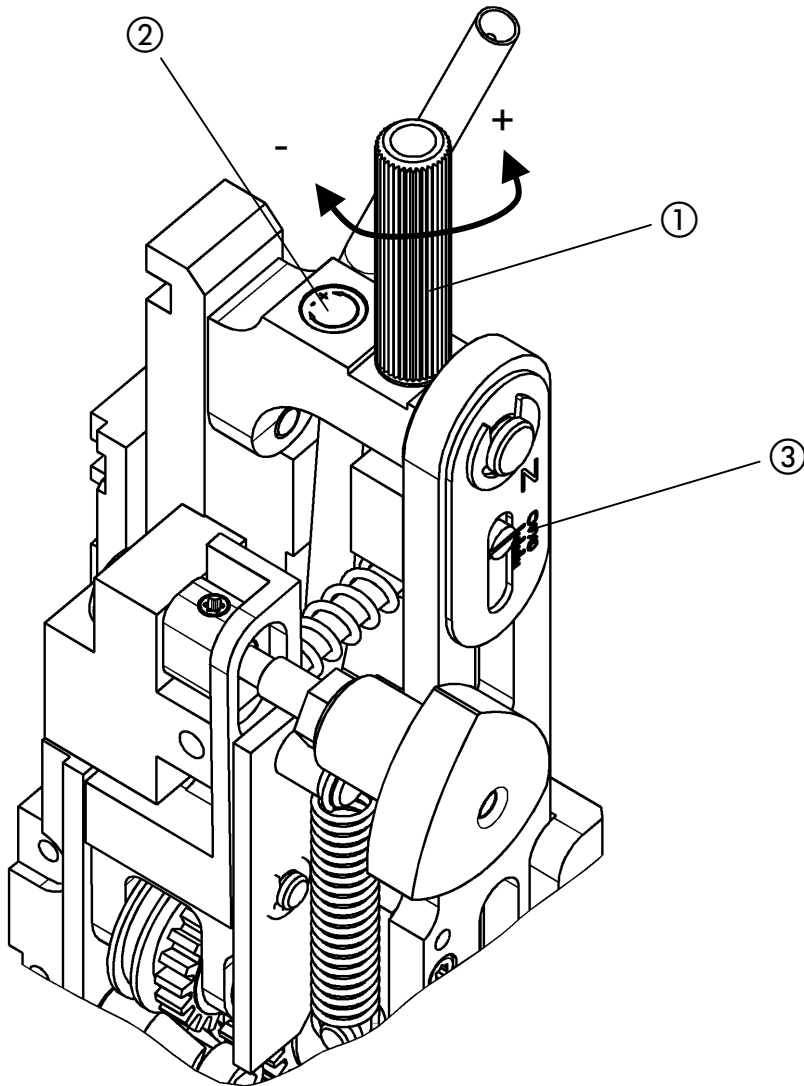

Fig. 11

3.6 Setting the stitch length

3.6.1 Basic setting of the stitch length

- Fig. 11 -

The setting is dependent on the thickness of the brochure sheets. Adjust notch on scale ③ by turning the knurled nut ①. One graduation line corresponds to approx. 1 mm stitch thickness. A slight correction may be necessary after changing the wire thickness.

Normal stitching:

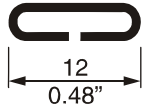

The recommended wire length for 2-sheet stitching is approx. 23 mm, the stitching unit must then be set to 2-sheet stitching.

3.6.2 Fine adjustment of the stitch length

- Fig. 11 -

Fine adjustment of the wire length is performed by means of test stitches. If the stitch is not the required length, more wire can be fed by **turning** knob ① **anticlockwise (+)**, or less wire can be fed by **turning** the knob **anticlockwise (-)** (cf. scale ②).

1 revolution of the knob feeds around 2 mm wire.

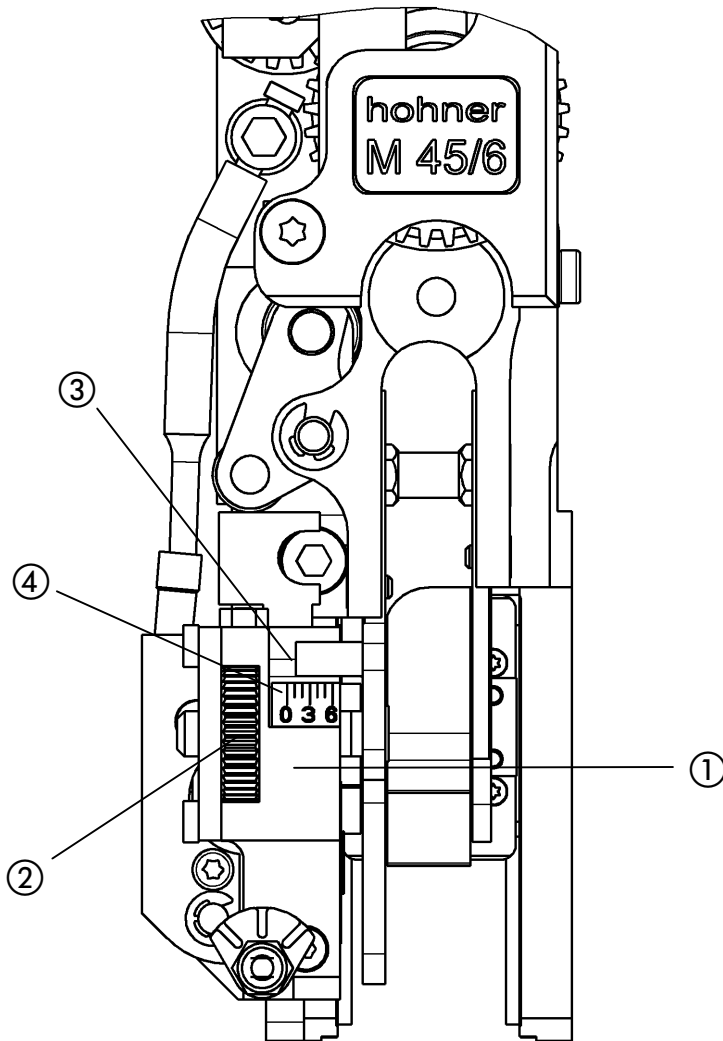

Fig. 12

3.6.3 Setting the leg length of the stitch

- Fig. 12 -

The leg length of the stitch is dependent on the thickness of the product to be stitched. The knife box ① can be adjusted in order to adapt to the thickness of the product. The end of the scale pin ③ marks the set value for the stitch thickness in mm on the scale ④ (0 - 6)..

- Adjust knife box ① by turning the knurled wheel ②, until the end of the pin ③ indicates the value of the required stitch thickness (in mm) on the scale.
- Test the leg length by a test stitch.
- Set the stitch to precisely the same leg length by turning the knurled wheel ②.

Normal stitch



move thumbwheel up



move thumbwheel down

Operation

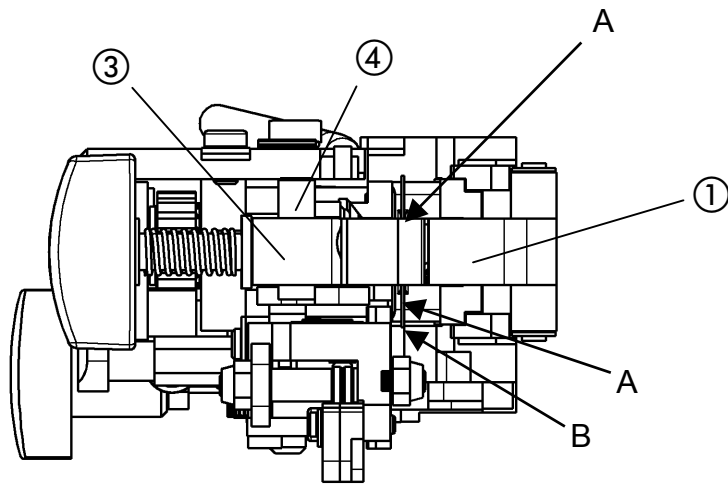

Fig. 13

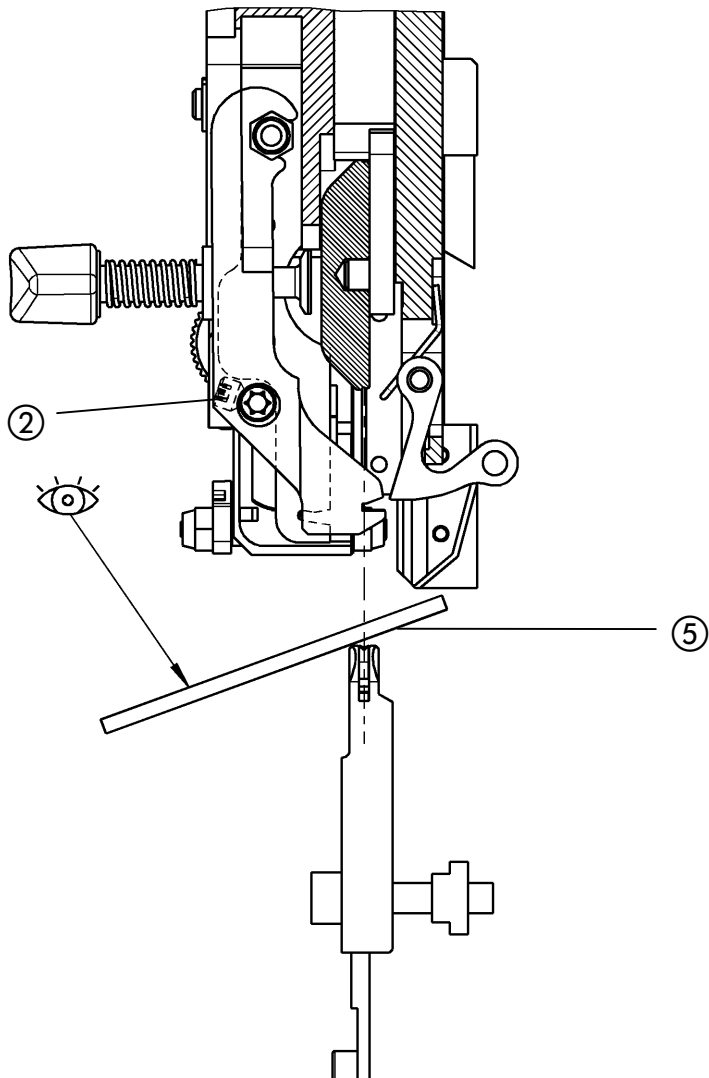

Fig. 14

3.7 Setting the former

- Fig. 13, Fig. 14 -

To guarantee perfect stitching, the former ③ must swivel in far enough for the stitching wire (arrow B) to be positioned exactly beneath the center of the groove (arrow A) of the bender ①.

A mirror ⑤ placed on the clincher box can be used to check the setting on the fitted stitching head. The former ③ must keep the wire (arrow B) exactly aligned with the groove (arrow A) of the bender ①.

- Loosen the clamping screw ②.
- Turn the eccentric former stop ④ until precisely aligned.
- Tighten the clamping screw ②.



When changing the stitching wire thickness, the former setting should be checked and corrected if necessary.

Operation

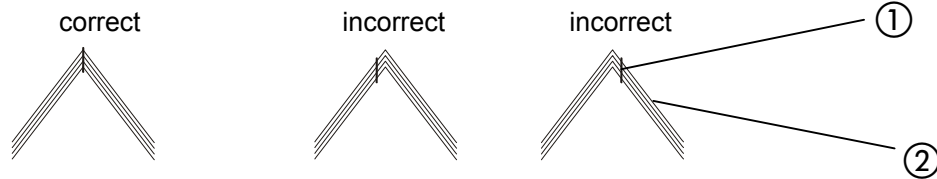

Fig. 15

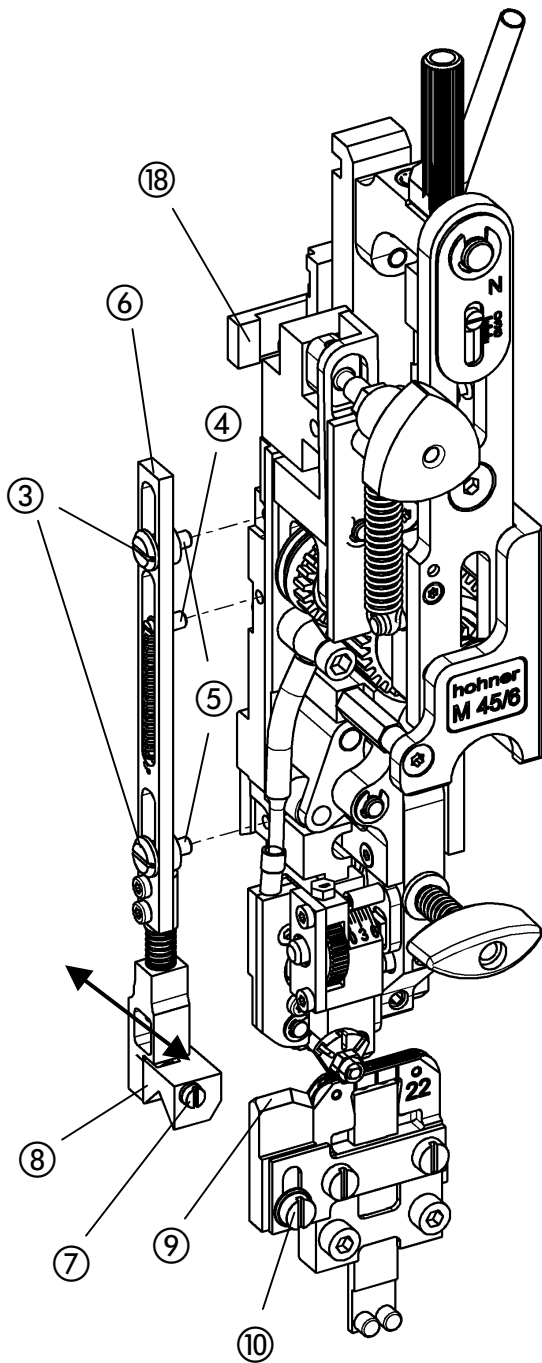

Fig. 16

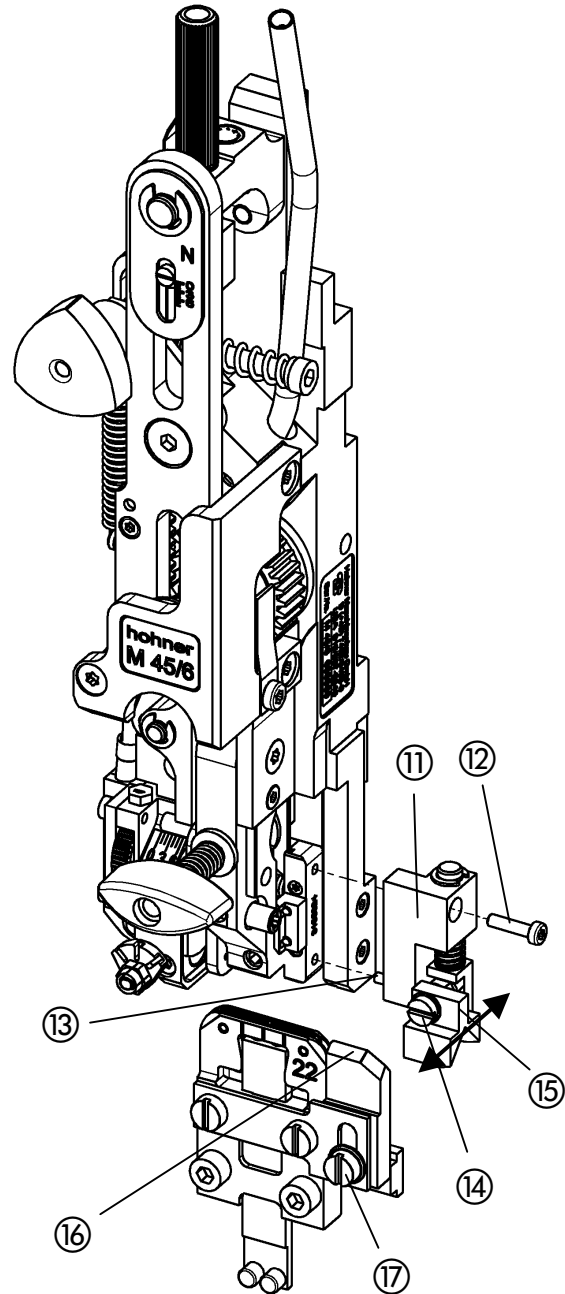

Fig. 17

3.8 Spine centering parts

The centering parts are only used for saddle stitching. They serve to precisely position the staple ① in the fold centre of the sheets ② (- cf. 15 -)

3.8.1 Installing the holding down device (standard version)

- Fig. 17 -

- In order to install the holding down device ⑪, insert the guide pin into the borehole on the bender and tighten the fastening screw ⑫.

3.8.2 Adjusting the holding down device (standard version)

- Fig. 17 -

- The centering prism ⑮ can be moved back and forth by turning the adjusting screw ⑭.
- Move the centering prism ⑮ backward or forward until it is precisely aligned with the prism of the slider ⑯.
 - Adjust the height of the prism ⑯ (approx. 0.5 mm above the clincher box) by moving it in the slot and tighten the fastening screw ⑰.

3.8.3 Installing the holding down device (optional narrow version)

- Fig. 16 -

- In order to mount the holding down device, screw the spring bolt ④ into the borehole on the stitching head.
- Insert extension spring into spring bolt ④ and lifting rod ⑥.
- Fix holding down device by screwing fastening screw ③ to lifting rod ⑥ and flange bushings ⑤ on the stitching head.
- Make sure that the lifting rod moves smoothly.
- Installing the carrier ⑱ in the main slide bar - see SPARE PARTS LIST page E27.

3.8.4 Adjusting the holding down device (optional narrow version)

- Fig. 16 -

- The centering prism ⑧ can be moved back and forth by turning the adjusting screw ⑦.
- Move the centering prism ⑧ backward or forward until it is precisely aligned with the prism of the slider ⑨.
 - Adjust the height of the prism ⑨ (approx. 0.5 mm above the clincher box) by moving it in the slot and tighten the fastening screws ⑩.

4 Servicing

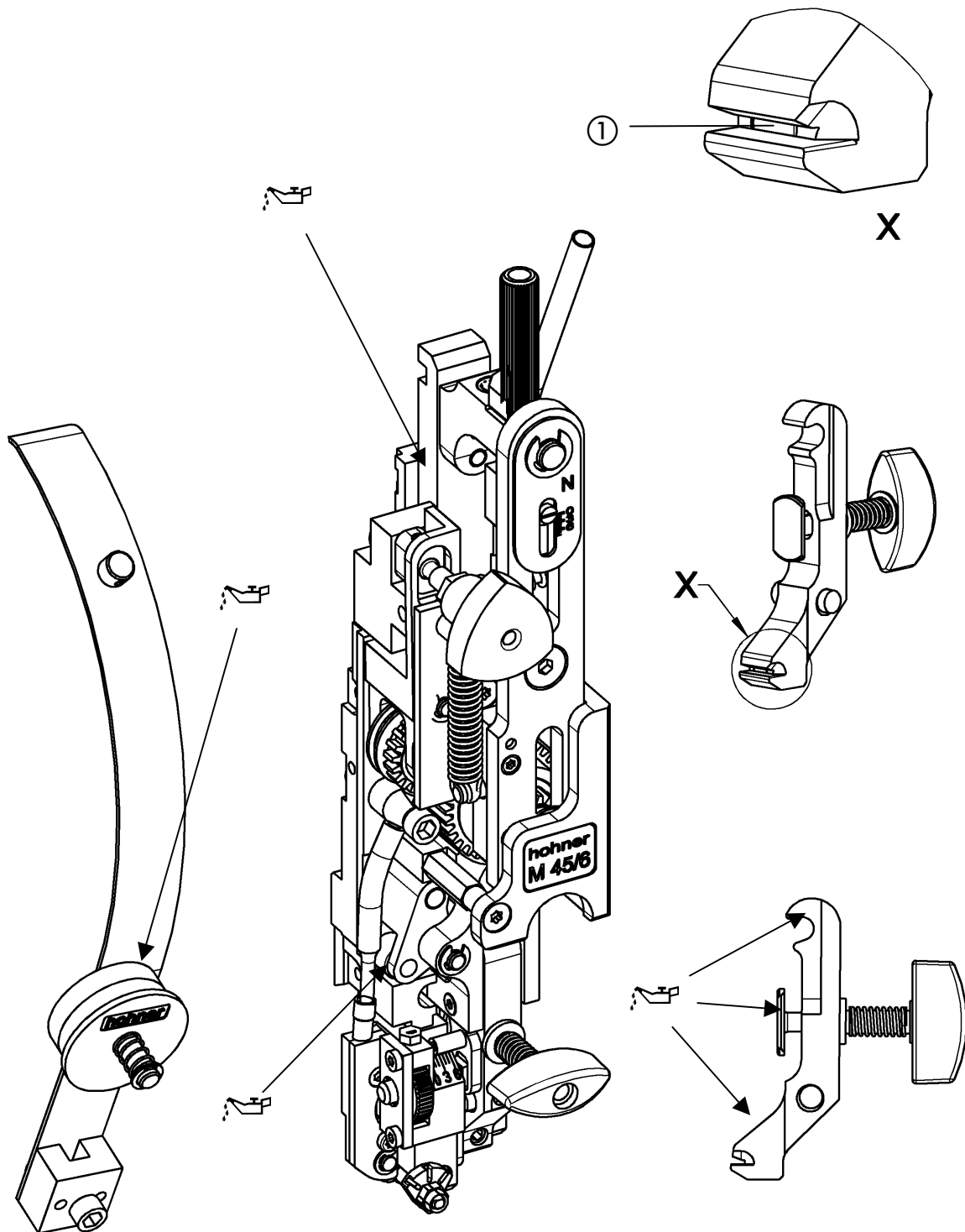

Fig. 18

4.1 Lubrication

- Fig. 18 -

After approx. 16 operating hours, the stitching head must be lubricated with the lubricants described below.

The felt disks of the wire feed spring must also be lightly lubricated from each day.



If the stitching head is not regularly lubricated, greater wear will occur, the service life of the stitching head will be considerably decreased and premature failure of the stitching head may occur.

The magnet ① in the former should be cleaned from time to time, in order to ensure optimal wire holding force.

4.1.1 Lubricants

Lubricating grease for guideways and friction points:

High temperature high performance grease

Recommendation: RIVOLTA s.k.D. 4002 (100 gr.) - Order no. 96 90 016

Oil for felt disks:

Guideway oil with viscosity class 65-70 (ISO- viscosity class in accordance with DIN 51 519).

4.1.2 Lubrication plan

<i>Date</i>	<i>Operating hours status - display on stitching unit</i>	<i>Oil or grease used</i>	<i>Performed by: Name Signature</i>

4.2 Installation and replacement of parts

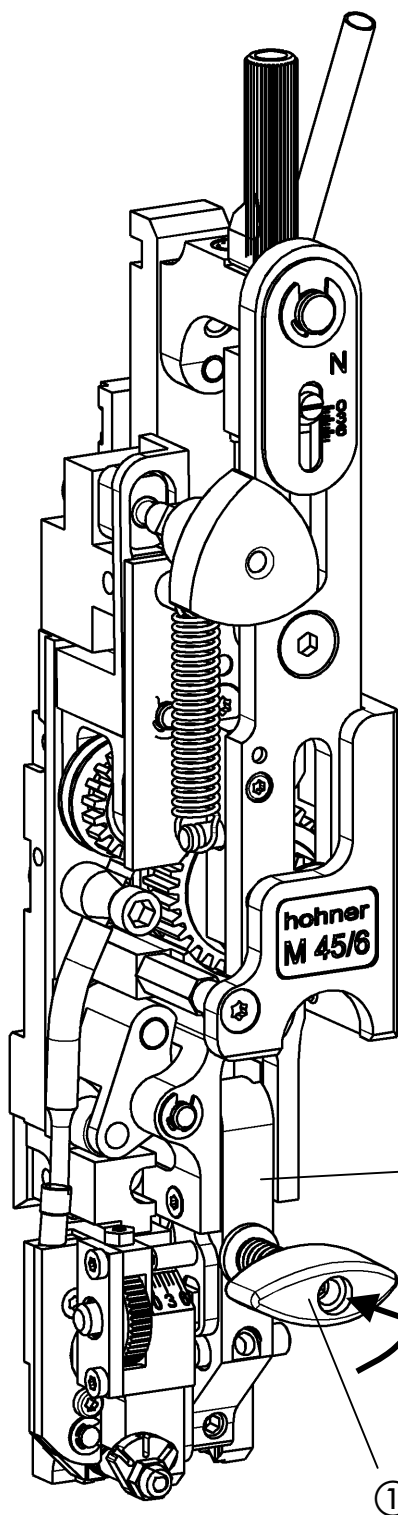

Fig. 19

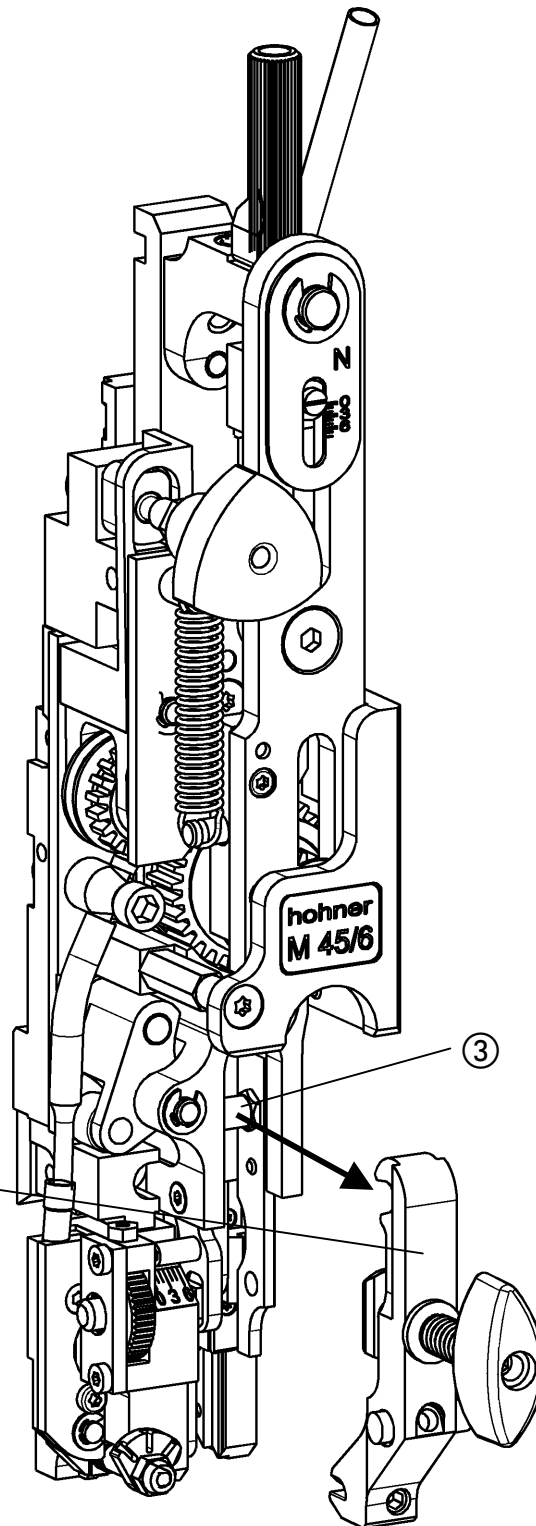

Fig. 20

4.2.1 Replacing the former

- Fig. 19, Fig. 20 -

- Push in clamping handle ① slightly and rotate by 90°. Remove former ② forwards.

Installation occurs in the reverse order. Make sure that the former is correctly positioned on the bolt ③.

- Adjust former according to Chap. 3.7.

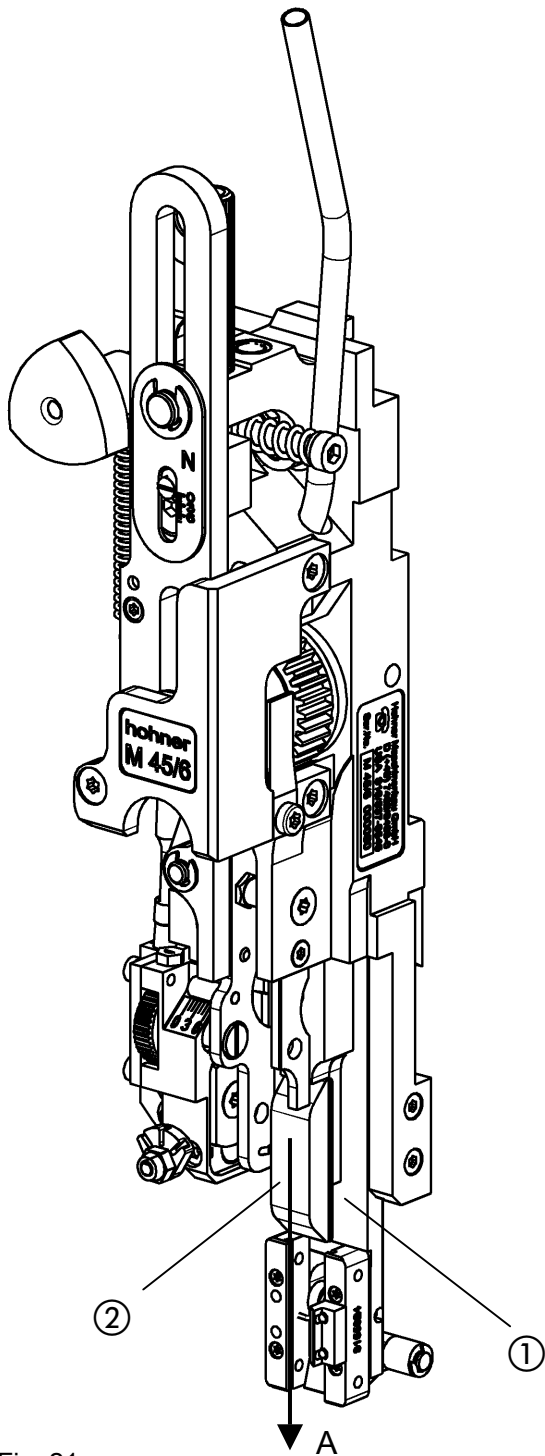

Fig. 21

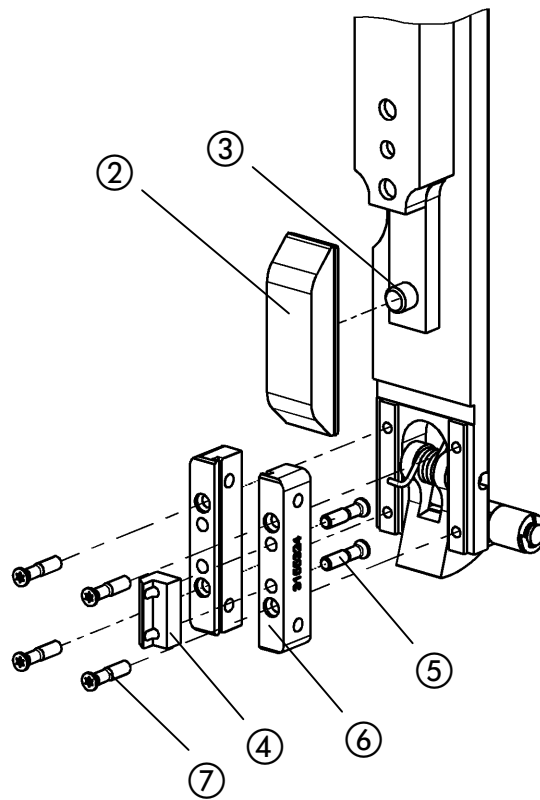

Fig. 22

4.2.2 Removing the bender stop

- Fig. 21, Fig. 22 -



The driver ② can be used on both sides. If one side is damaged or worn, the driver can be turned round.



Driver and bender are numbered. You must ensure that only drivers with matching benders (see table below) are used, as their wire guidance grooves vary.

Round wire no. 24 - 26 Driver : 31 55 334	with bender: 31 55 324
Round wire no. 26 - 28 Driver : 31 55 336	with bender: 31 55 326
Round wire no. 23 Driver : 31 55 334	with bender: 31 55 323

To replace or turn the driver, the central slide must be pulled down completely (arrow A).

- Remove central slide with driver ② downwards from stitching head (arrow A).
- Remove driver ② from driving pin ③.
- Turn or replace driver ②.

Installation occurs in the reverse order.

4.2.3 Replacing the bender

- Fig. 21, Fig. 22 -

To replace or turn the bender, the main slide ① must be pulled down completely (arrow A).

- Remove main slide ① with bender ⑥ downwards from stitching head (arrow A).
- Remove bender ⑥ by loosening the screws ⑦.
- Remove stop prism ⑥ by loosening the screws ⑤
- Turn or replace bender ⑥.

Installation occurs in the reverse order.

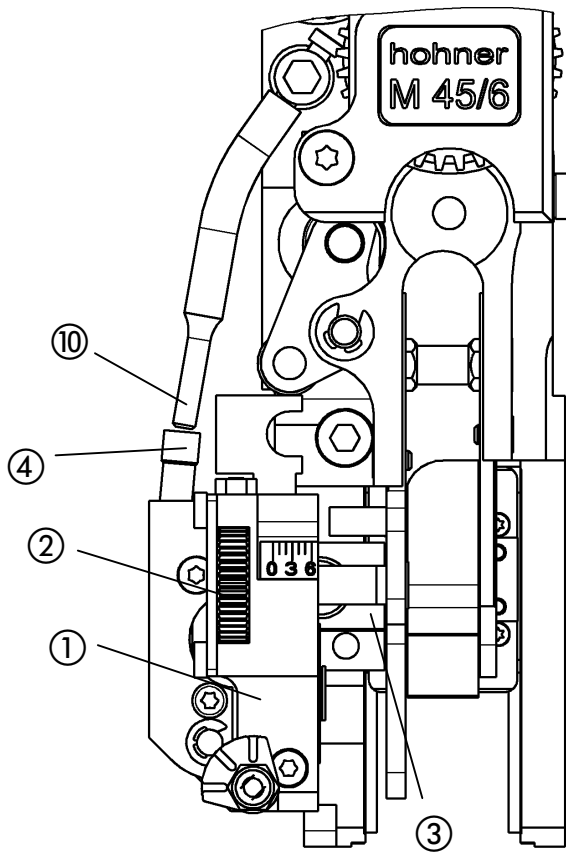

Fig. 23

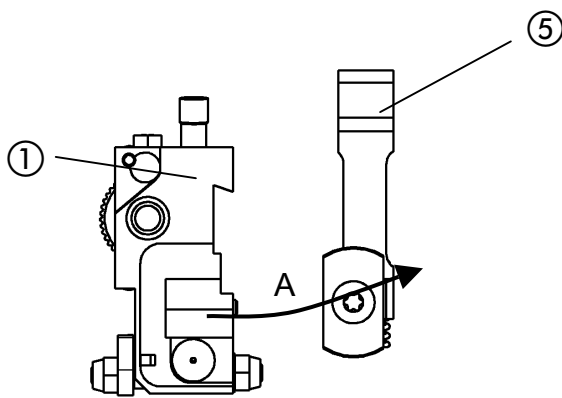

Fig. 24

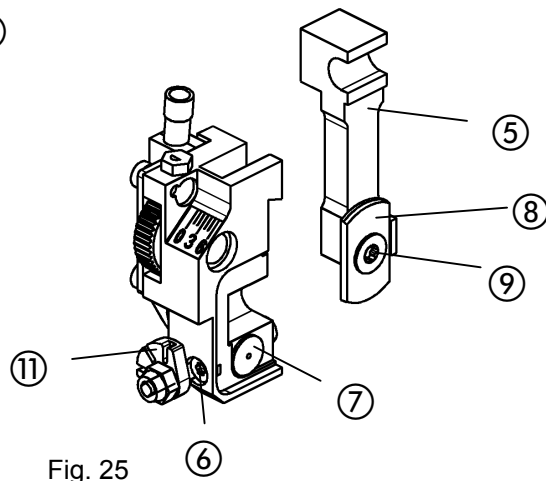

Fig. 25

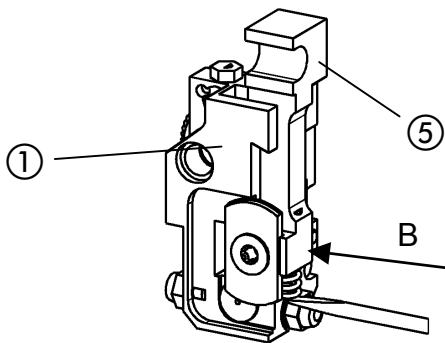

Fig. 26

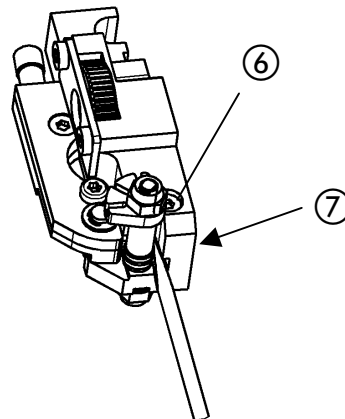

Fig. 27

4.2.4 Replacing the knife

- Fig. 23 -

- To replace the knife, move the knife box ① completely away from the guide ③ by turning the knurling wheel ② and remove from the stitching head.

- Fig. 24 -

- Push the knife slider ⑤ out of the knife box ① (arrow A)
Make sure that the pressure spring doesn't strip.



- Change the knife (see following chapter)

- Fig. 26 -

- Replace knife slider ⑤ in the knife box ① (arrow B), compressing the pressure spring of the knife slider with a screwdriver, and pushing it into the knife box. Make sure that the pressure spring is not bent.



- Fig. 23 -

- Place knife box ① on the guide ③.
- Attach flexible wire feed to drill hole ④ in knife box.
- Return knife box to the desired position by turning the knurling wheel.



4.2.4.1 Rotating/Changing the flat knife

- Fig. 25 -

The flat knife has 2 cutting edges. Each cutting edge can be used three times by means of rotation.

- Loosen and unscrew fastening screw ⑨.
- Rotate or replace flat knife ⑧ and tighten fastening screw ⑨.



4.2.4.2 Replacing the circular knife

- Fig. 25 -

- Set position of the wire straightening eccentric ⑩ to the left until the clamping screw ⑥ is accessible.
- Loosen the clamping screw ⑥ and remove the circular knife ⑦.
- Press new circular knife completely into the seat in the knife box.
- Adjust circular knife (cf. Adjusting the circular knife).

4.2.4.3 Adjusting the circular knife

- Fig. 27 -

The circular knife is adjusted so as to ensure clean cutting of the wire.

When the knives are mounted, set the clearance between the flat and circular knives by carefully "levering" with a screwdriver.

- Loosen clamping screw ⑥ and position circular knife ⑦ exactly against the flat knife by "levering" with a screwdriver.
- Tighten clamping screw ⑥.
- After having installed the knives box ① align the stitching wire according to chapter 3.5 if necessary.



If the distance between the knives is set too close the knife slider 5 may block and cause a wire jam.

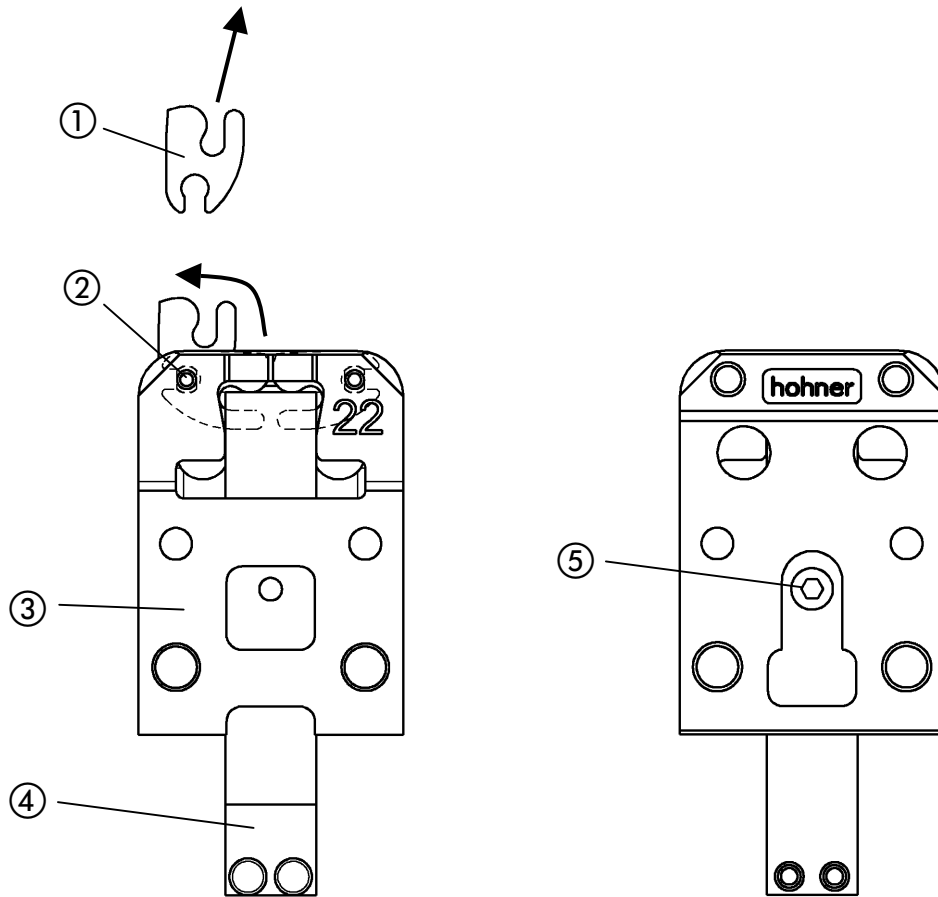

Fig. 28

4.2.5 Replacing the driver

- Fig. 28 -

- Unscrew locking screw ⑤.
- Remove clincher ram ④ downwards.
- Turn clincher ① upwards in clincher box ③ and remove from the locking pin ②.
- Push new clincher onto the locking pin and turn to center of clincher box.
- Re-introduce clincher ram.
- Screw in and tighten locking screw ⑤.











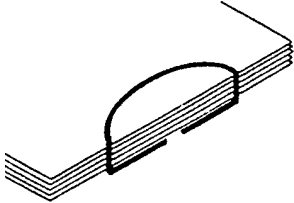
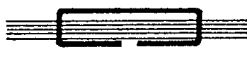

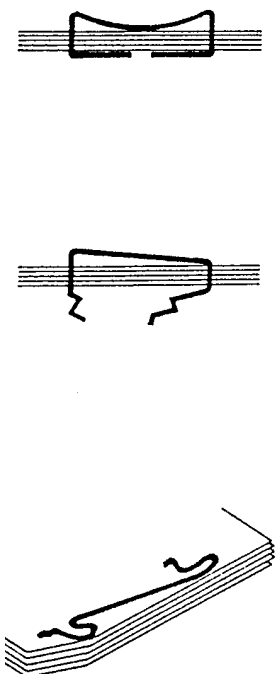

Make sure that you use the right screw-in side of the locking screw ⑤.

5 Faults

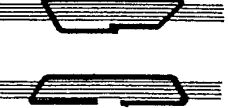
5.1 Causes and elimination of faults

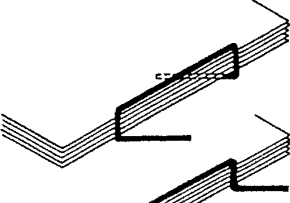
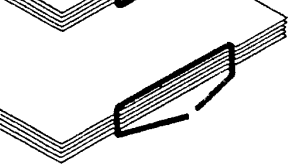
Below you will find some examples of faults, with information on the potential cause. If various causes come into consideration, sometimes several suggestions may be made for the remedy: You should not follow all of these before testing the result, but proceed step by step, with intermediate testing. Worn parts should always be replaced.

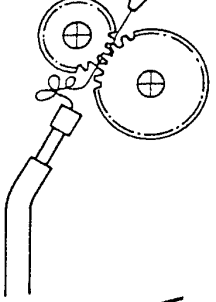
Stitch	Fault	Potential cause and elimination of the fault
	Back of stitch is bent in a banana shape:	<ul style="list-style-type: none"> - Weak or soft wire. - Wire not aligned, cf. 3.5. - Circular or flat knife worn, cf. 4.2.4. - Shoe tongue pressure too weak: remove obstructing wire pieces or replace pressure spring in shoe tongue. - Wire groove in driver soiled, worn or damaged: remove driver, cf. 4.2.2. Clean driver groove or replace driver.
	Back of stitch not securely positioned:	<ul style="list-style-type: none"> - Stitching not pressed sufficiently: set stitching unit to stitch thickness.
	Stitch legs are not sufficiently clinched:	<ul style="list-style-type: none"> - Stitching not pressed sufficiently: set stitching unit to stitch thickness. - Clincher is not coming up far enough: adjust clincher lift pressure on stitching unit. - Time from clincher activation to lift movement is incorrect: stitching unit must be reset by the manufacturer.
	Back of stitch is not securely positioned and is sagging in a saddle shape:	<ul style="list-style-type: none"> - Stitching not sufficiently pressed: set stitching unit to stitch thickness. - Weak or soft wire. - Shoe tongue pressure too weak: remove obstructing wire pieces or replace pressure spring in shoe tongue.
	Stitch legs are buckled and are not properly clinched:	<ul style="list-style-type: none"> - Weak or soft wire. - Wire not aligned, cf. 3.5. - Align clincher box, cf. 3.1.4. - Different leg lengths, cf. 3.6.3. - Overall wire piece too short, cf. 3.6.2. - Circular or flat knife worn, cf. 4.2.4.
	Wire not penetrating, resulting in loop formation:	<ul style="list-style-type: none"> - Weak or soft wire. - Bender groove blocked by wire pieces. - Circular or flat knife worn, cf. 4.2.4. - Wire groove in driver soiled, worn or damaged: remove driver: clean driver groove or replace driver, cf. 4.2.2. - Shoe tongue pressure too weak: remove obstructing pieces of wire or replace pressure spring in shoe tongue. - Align clincher box, cf. 3.1.4.

	<p>Stitch legs break off:</p>	<ul style="list-style-type: none"> - Wire too brittle: use a different wire quality. - Former blocked by pieces of wire: remove wire pieces, remove former if necessary. - Gripper spring or gripper in former defective. - Wire thickness not suitable for the wire guiding parts (bender and driver). - Adjust former to bender groove.
	<p>Hump at a stitch corner:</p>	<ul style="list-style-type: none"> - Weak or soft wire. - Driver damaged, cf. 4.2.2. - Circular or flat knife worn, cf. 4.2.4. - Wire not aligned, cf. 3.5. - Circular or flat knife worn, cf. 4.2.4.
	<p>Stitch legs contract or diverge:</p>	<ul style="list-style-type: none"> - Wire not aligned, cf. 3.5. - Align clincher box, cf. 3.1.4.
	<p>Leg ends clinched the wrong way round:</p>	<ul style="list-style-type: none"> - Weak or soft wire. - Wire not aligned, cf. 3.5. - Circular or flat knife worn, cf. 4.2.4.
	<p>One or both legs are clinched obliquely:</p>	<ul style="list-style-type: none"> - Clincher damaged, cf. 3.1.3. - Adjustment of clincher box mounting to stitching head mounting, cf. 3.1.4. - Wire not aligned, cf. 3.5.
	<p>Stitch legs are clinched obliquely to the same side:</p>	<ul style="list-style-type: none"> - Adjustment of clincher box mounting to stitching head mounting, cf. 3.1.4. - Wire not aligned, cf. 3.5. - Bender worn, cf. 4.2.3.
	<p>Lightly bent wire pieces fall out:</p>	<ul style="list-style-type: none"> - Wire not aligned, cf. 3.5. - Cutting slider jammed: circular knife set too tightly to flat knife, cf. 4.2.4.3. - Cutting rocker locked, pressure spring in cutting block defective.
	<p>Wire loop between conveyor wheels and wire guidance tube:</p>	<ul style="list-style-type: none"> - Lower wire tube in cutting block has shifted: adjust slightly up or down. - Former incorrectly set, cf. 4.2.1.
	<p>Straight wire pieces fall out:</p>	<ul style="list-style-type: none"> - Weak spring pressure on former. - Wire not aligned, cf. 3.5. - Former set incorrectly, cf. 4.2.1.